



**A Code of Practice for the
Safe Installation, Operation and Maintenance
of Thermal Spraying Equipment**

Disclaimer

In the production of this Code, the Thermal Spraying and Surface Engineering Association has endeavoured to use the best sources of information known to the Association at the date of publication of the Code. The advice and information are given in good faith and belief of their accuracy. The Code is intended for use by technically competent persons and its use does not, therefore, remove the need for technical and managerial judgement when applying the Code in practical situations and with due regard to local circumstances, nor does it confer any immunity or exemption from relevant legal requirements, including bye-laws.

The onus of responsibility for the application of the guidance in this code is that of the user. The Association, its officers, its members and the individual members of any Working Parties can accept no legal liability or responsibility whatsoever, howsoever arising, for the consequences of the use or misuse of the Code.

For the assistance of users, references are given in the text to sources of information on current Legislation, British Standards and other Codes of Practice relevant at the time of publication that may be applicable. This Code is intended to be read and used in the context of these references where the subjects have a bearing on the local application of the processes or operations carried out by the user.

It should be noted that such documents are continually being updated and whilst the references listed are up to date as at the date of publication, it is advisable to check these before acting upon them.

Preface

This guide outlines how a new installation to operate thermal spraying equipment should be installed and operated. Existing installations must comply so far as is reasonably practicable.

This document, which represents best practice within the industry, was prepared by a committee of the Thermal Spraying and Surface Engineering Association in conjunction with the Health and Safety Executive who were represented on the committee at all stages of its preparation.

Preface to Second Edition

The guide has been reviewed and updated in order to take account of changes in legislation and standards between its original date of publication (2001) and 2009.

In particular users should note that:

- legislation concerning substances hazardous to health has been revised to introduce workplace exposure limits,
- noise legislation has been revised to reduce the action levels and introduce an exposure limit,
- legislation has been introduced to define duties in relation to dangerous substances and explosive atmospheres, with a complementary duty in relation to fire precautions.

Acknowledgements

This Code of Practice was prepared as a result of an initiative by the Committee of Management of the Thermal Spraying and Surface Engineering Association. For this purpose a special Health and Safety Committee was formed, chaired by Dr F J Blunt. The following people contributed to the production of this booklet

Tom Ashworth	Malbeth Ltd
Noel Bickley	NB Services
Jane Blunt	Chair University of Cambridge (formerly employed by TWI)
Mark Cole	BOC Gases
Geoff Creffield	Consultant
Chris Davies	Health and Safety Executive
Gareth Davies	Praxair TAFE Technologies
Bob Easterby	Health and Safety Executive
Jeff Fairweather	Health and Safety Executive
John Gent	Rolls-Royce plc
Chris Guest	Praxair Surface Technologies Ltd
Keith Harrison	Sulzer Metco (UK) Ltd
Anthony Herbert	Sulzer Metco (UK) Ltd
Ivor Hoff	TSSEA
Richard Jones	IOSH (formerly employed by Rolls-Royce plc)
Doug Keyworth	Dowding and Mills Engineering Services
Phil Lavin	Monitor Coatings Ltd
Steve Lees	HNTS
Terry Lester	Metallisation Ltd
Ron Lucas	Rolls-Royce plc
John Powell	Health and Safety Executive
Mike Round	South Staffs Industries Ltd
David Sansom	Sermatech Ltd
Andy Sturgeon	TWI
Adrian Weatherill	Sermatech Ltd
Dave Winder	Q Coat Ltd

The following people contributed to the revised edition, 2014:

Andrew Cole	TSSEA
Mike Round	South Staffs Industries Ltd
Ken Lawson	University of Cranfield
Terry Lester	Metallisation Ltd
Mark Cole	BOC Gases
Steve Bomford	Sulzer Metco
Ray Bowen	Praxair
Terry Hirst	Aero Engine Controls
Mark Gee	National Physical Laboratory
Melissa Riley	TWI Ltd
Tiziana Marrocco	TWI Ltd

Issue Information

Code of Practice for the Safe Operation of Thermal Spraying Equipment

Issue 3, July 2014

Contents

1. Scope
2. Definitions
3. Outline of Employers Duties
4. Description of process within the scope of this guide
 - 4.1 Flame Spraying
 - 4.2 Arc Spraying
 - 4.3 Plasma Spraying
 - 4.4 High Velocity Spraying (HVOF)
 - 4.5 Cold Spraying
5. Key hazards in the operation of thermal spray equipment
 - 5.1 Introduction
 - 5.2 Compressed gases
 - 5.3 Noise
 - 5.4 Radiant energy
 - 5.5 Fume and dust
 - 5.6 Combustion Products
 - 5.7 Water-borne disease
 - 5.8 Mechanical hazards
 - 5.9 Electricity
 - 5.10 Cryogenic Gases
 - 5.11 Summary table
6. Design, construction and installation of equipment
7. The operational stage
 - 7.1 Training
 - 7.2 Gases
 - 7.3 Noise
 - 7.4 Radiation
 - 7.5 Fume and dust
 - 7.6 Mechanical hazards
 - 7.7 Electrical
8. Modifications
9. Maintenance and repair
 - 9.1 Introduction
 - 9.2 Gas systems
 - 9.3 Ventilation system and dust disposal
 - 9.4 Wet systems
 - 9.5 Electrical maintenance
- 10 Contingencies and emergency provision
11. References

Appendices

- A1. Thermal spray equipment pre-installation flow chart
- A2. Equipment location selection checklist
- A3. Equipment location selection flowchart
- A4. An example of zoning after Hazardous Area Classification
- A5. Checklist for installation and commissioning of a fully enclosed thermal spray booth
- A6. System of work for spraying operations in an extracted booth
- A7. Spraying in an open workshop using a lathe to traverse the workpiece (any thermal spray system)
- A8. A risk assessment and method statement for a spraying operation carried out on site - anti-corrosion treatment using zinc

1. Scope

1.1 This booklet is intended as an industry guide for the users and operators of thermal spray equipment, to assist in the establishment of safe practices within the industry.

1.2 It provides advice regarding the avoidance of the hazards associated with the following processes:

- Flame Spraying
- Arc Spraying
- Plasma Spraying and
- High Velocity Oxy-Fuel spraying, (HVOF)
- Cold Spraying (also known as cold dynamic gas spraying (CDGS)),

whether applied manually or by mechanised means, and for all types of consumables - metals, ceramics, mixtures, composites and polymers, as appropriate to the spray technique and the requirements of the coating. The five processes represent two that have a fuel as the energy source - flame spray and high velocity oxy-fuel spraying, two that use an electrical source - arc spray and plasma spray and one which relies mainly on a supersonic gas stream. Thus there are hazards that are common to all the processes, and some that are specific to one or two only. These differences are indicated in this booklet, with some indication of the relative importance in each process.

2. Definitions

2.1 **Explosive gas atmosphere:** A mixture with air, under atmospheric conditions, of a flammable material in the form of a gas or vapour in which, after ignition, combustion spreads throughout the unconsumed mixture

NB - Although a mixture which has a concentration above the upper explosive limit (UEL) is not an explosive gas atmosphere, it can readily become so and, in certain cases for area classification purposes, it is advisable to consider it as an explosive gas atmosphere.

2.2 **Hazardous area:** An area in which an explosive gas atmosphere is present, or may be expected to be present, in quantities such as to require special precautions for the construction, installation and use of apparatus. Hazardous areas are classified into one of three zones, 0, 1 and 2, depending on the frequency and duration of an explosive gas atmosphere occurring.

2.3 **Operator:** The person who will operate the equipment from day to day

2.4 **User:** The organisation that has purchased and installed the equipment, and whose employees will operate it.

2.5 **Zone 0:** An area in which an explosive gas atmosphere is present continuously or for long periods (this is defined as more than 1000 hours per year). *Example: At the spray gun tip before/after ignition or when the flame goes out.*

- 2.6 **Zone 1:** An area in which an explosive gas atmosphere is likely to occur in normal operation (this is defined as less than 1000 hours, but more than 10 hours per year). *Example: Inside the spray booth. The immediate area around the flammable gas stores.*
- 2.7 **Zone 2:** An area in which an explosive gas atmosphere is not likely to occur in normal operation and, if it does occur, is likely to do so only infrequently and will exist for a short period only (this is defined as less than 10 hours per year). *Example: The area around a flange, connection or other pipe fitting that is not expected to release flammable material during normal operation.*

3. An outline of the employer's duties

- 3.1 All employers have duties towards their employees to ensure, so far as is reasonably practicable, their health, safety and welfare while they are at work. These duties are outlined in the Health and Safety at Work Act, 1974.¹ These duties also extend to people who they do not employ but who may be affected by their undertaking; this may include members of the public, clients and contractors, inspectors from the Health and Safety Executive and other officials when they visit the premises, and those in the vicinity who would be at risk from fire, explosion, emissions etc.
- 3.2 Employers have a duty to manage safety by allocating responsibilities to individuals. There is also a requirement to obtain competent advice. Employers must assess the risks to which their employees and others are exposed, make arrangements for their control, and ensure that all legal requirements are met. Arrangements must include adequate training and refresher training, and such health surveillance as is appropriate to the risks. They must also make plans for emergencies, to include fire and explosion. These requirements are outlined in the Management of Health and Safety at Work Regulations.²
- 3.3 The Management Regulations² explicitly require the employer to undertake risk assessments. Risk Assessment has five stages^{3,4}
1. Look for the significant hazards.
 2. Decide who may be harmed and how.
 3. Evaluate the risk, and decide whether the control measures are adequate - if not, then consider whether the hazard can be removed altogether or the control measures can be improved.
 4. Document the findings (this is a legal requirement where an employer has five or more employees).
 5. Review, in particular if evidence shows that the risks are greater than at first thought, if working methods change, or if technological advances render the assessment invalid.

3.4 The employer must comply with the:

- Provision and Use of Work Equipment Regulations,⁵
- Manual Handling Operations Regulations⁶ for the handling or lifting of loads, and/or the Lifting Operations and Lifting Equipment Regulations,⁷
- Workplace (Health, Safety and Welfare) Regulations⁸ in relation to the workplace itself and its basic facilities,
- Control of Noise at Work Regulations,⁹
- Control of Substances Hazardous to Health Regulations,¹⁰
- Dangerous Substances and Explosive Atmospheres Regulations,¹¹
- Regulatory Reform (Fire Safety) Order,¹²
- Electricity at Work Regulations¹³, and
- Environmental Protection Act.¹⁴

However, note that this is not an exhaustive list.

3.5 This code of practice gives an overview of the key hazards that should be considered in a thermal spraying operation, gives further guidance relating to the legal constraints that apply, and suggestions regarding the control of risk. However, it must be stressed that employers must apply the knowledge from this booklet, and other sources of information to their own particular circumstances.

4. Description of processes within the scope of this guide

4.1 Flame Spraying

4.1.1 A torch burning acetylene, propane, propylene or hydrogen with oxygen is used - see Figure 1. The spray consumable is in the form of a wire, cord or a powder. Wire or cord consumables are fed into the centre of the flame where the material is melted and propelled by the atomising gas towards the component. In powder spraying, the consumable is supplied to the gun in powdered form, and heated to the plastic or molten form in the gas flame. In some cases an additional gas jet is used to accelerate the powder particles.

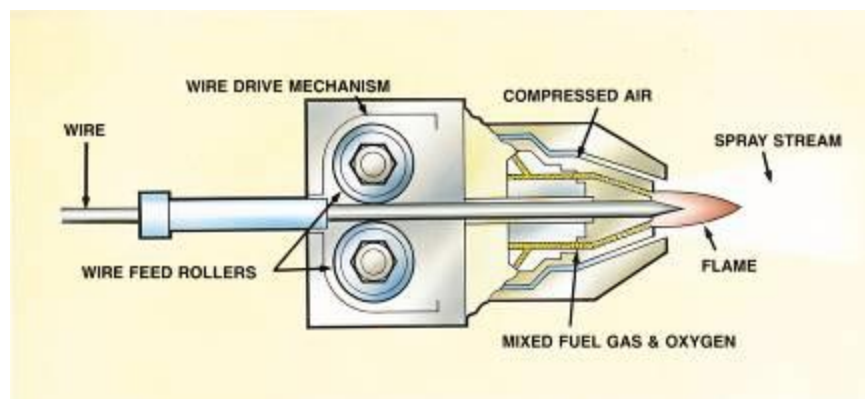

Figure 1(a) Wire Flame Spray

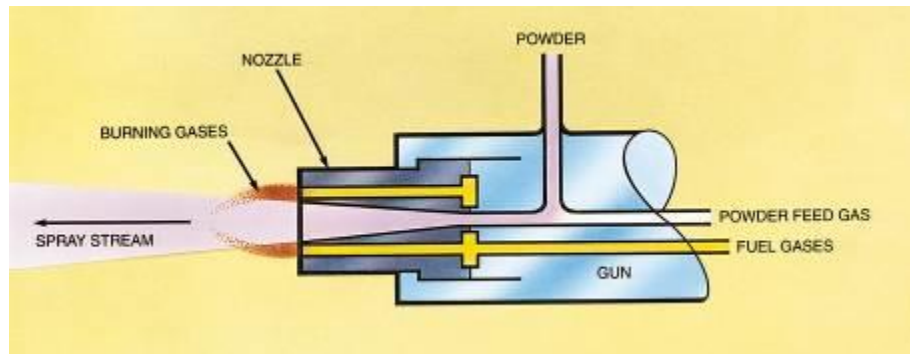

Figure 1(b) Powder flame spray

Figure 1: Flame spray process schematics (pictures courtesy Metallisation Ltd)

4.1.2 The process requires a flame spraying gun, gas delivery and storage. It is a process that can easily be transported to site, and is generally operated manually. However, the process can be programmed.

4.2 Arc Spraying

4.2.1 In the arc spray process, a DC electric arc is struck between two consumable wires, which are fed continuously into the gun. The molten material is atomised and propelled towards the component by a compressed air (or in very specialised applications, inert gas) jet, see Figure 2.

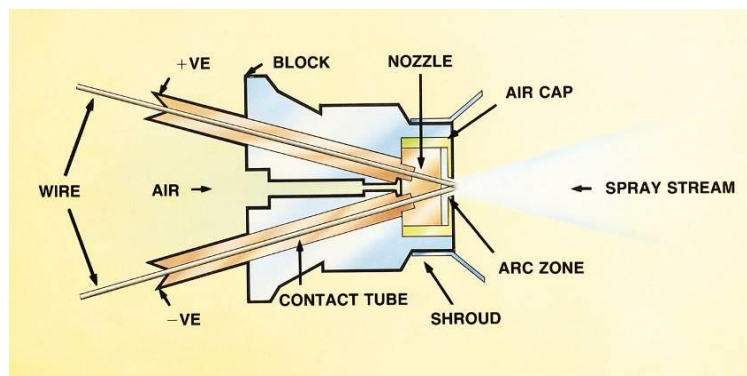

Figure 2: Arc Spray (Picture courtesy Metallisation Ltd)

4.2.2 The process requires an arc gun, power supply (usually constant voltage) with twin wire feed unit, and a compressed air or inert gas supply. It is readily transported to site applications, for example to spray bridges and offshore structures. It is also suited to mechanised application, where the gun and/or the component can be manipulated by a robot or turntable.

4.3 Plasma Spraying Processes

- 4.3.1 In plasma spraying, a DC electric arc is struck between two non-consumable electrodes, while a flow of inert gas is fed through the arc. This generates a stream of ionised gas which is heated and expanded and then accelerated by the torch nozzle so that it emerges as a high velocity plasma jet. Plasma gases are commonly argon, hydrogen, helium or nitrogen, or mixtures of these. Powder particles are fed in an inert gas into this plasma, where they are heated and propelled to the component - see Figure 3.
- 4.3.2 There are two distinct variants - vacuum or low pressure plasma spraying, which is conducted inside an evacuated chamber, and air plasma spraying which is carried out at normal pressures. Provision may be made to cool the component during spraying, using cryogenic gases. The gun itself requires water cooling.

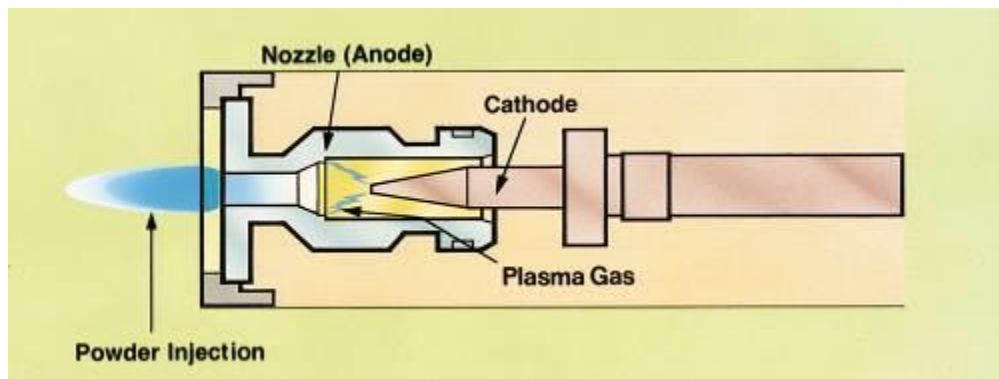

Figure 3: Plasma Spray (Picture courtesy Metallisation Ltd)

- 4.3.3 The equipment needed includes a power supply (usually constant current), a plasma gun, powder feed unit, process control console, gas delivery system and a heat exchanger. Air plasma spray would generally be operated within an enclosed booth with fume and dust extraction to protect the operator from the noise, fume, dust and ultraviolet light. Mechanised, automated or robotic manipulation may be required to apply the coating. The reduced pressure variants would require a purpose built chamber and vacuum pumps.

4.4 High Velocity Oxy-fuel Spraying, HVOF

- 4.4.1 In this process, the gun has been designed to burn the oxy-fuel mixture in a combustion chamber. High gas flow rates and high pressures within the system lead to the generation of supersonic flames emerging from the gun - up to 2000 m s^{-1} . Fuels include gases such as acetylene, hydrogen, propane, propylene and liquid fuels such as kerosene. The consumable is fed as a powder entrained in an inert gas into the gun, where it is heated and propelled by the flame towards the component, see Figure 4. The component may be cooled if required.

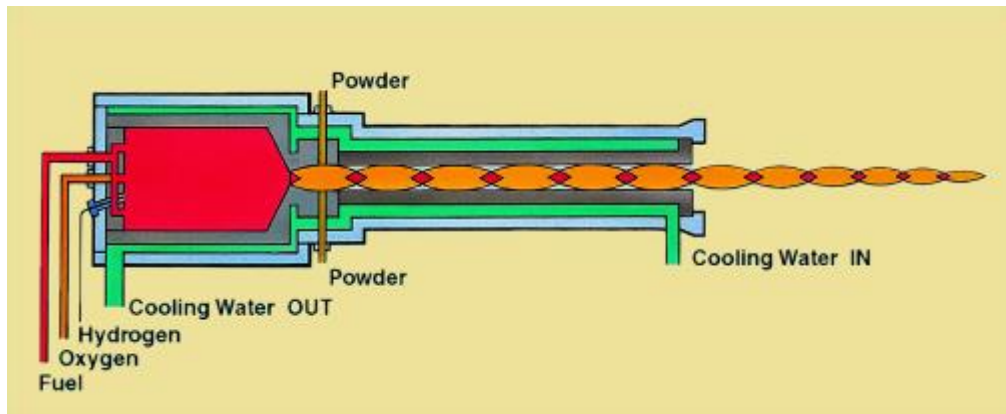

Figure 4: High Velocity Oxy-Fuel Spraying, HVOF (A Liquid Fuelled Example) (Picture courtesy Metallisation Ltd)

4.4.2 The equipment needed includes the spray gun and its cooling circuit and heat exchanger, gas flow control unit, gas delivery system, powder feed unit, and mechanised or robotic manipulation of the gun and/or component. The process is very noisy, and an sound attenuated enclosure with fume and dust extraction will be required which will also extract the combustion products.

4.5 Cold Spraying

4.5.1 Cold spray, or more precisely Cold Gas Dynamic Spraying (CGDS) is a coating technology that involves the deposition of metallic layers and structures from fine powders propelled using high pressure, high flow gases, see Figure 5^{63,64,65}. Momentum transfer from the supersonic gas jet to the particles results in a high velocity particle jet (at 200 to 1000ms⁻¹). In this way, upon impact with the target surface, the solid powder particles experience plastic deformation that disrupts thin surface films (such as metal oxides), thus providing intimate conformal contact between clean metal surfaces under high local pressure. This permits bonding to occur, and layers of deposited material can be built up rapidly.

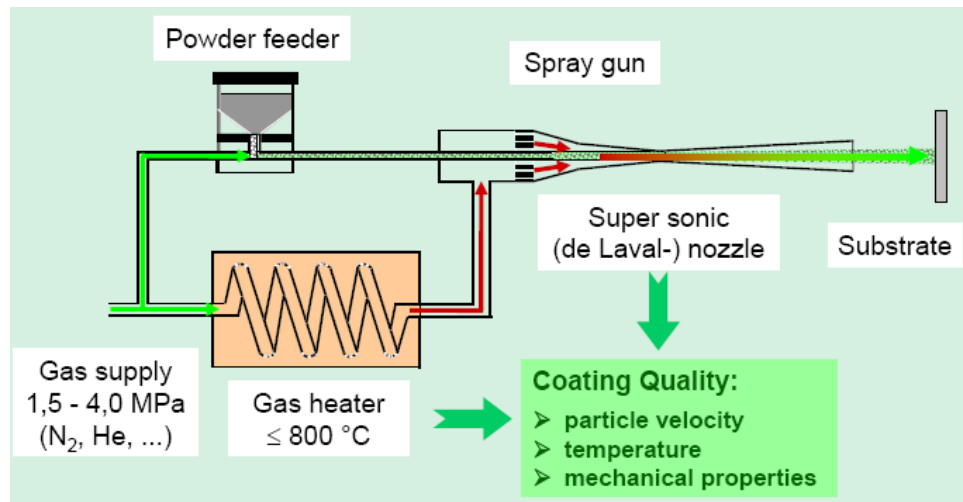

Figure 5 Schematic of cold spray system (image courtesy of HC Stark).

4.5.2 The basic elements of all cold spray set-ups are the spraying unit (consisting of a pre-chamber and supersonic nozzle), powder feeder, gas heater, source of a compressed gas, spray chamber with a motion system, and system for monitoring and controlling spray parameters.

5. Key hazards in the operation of thermal spray equipment

5.1 Introduction

5.1.1 In this section, the key hazards associated with thermal spraying are described. The section includes a brief description of the hazards and their possible consequences. In any risk assessment for a thermal spray process a consideration of all relevant hazards will need to be included. Ancillary activities that are likely to be undertaken, such as grinding, grit blasting, solvent cleaning, machining, etc, are not included in this booklet.

5.2 Compressed Gases

Key Hazards: *Unintended pressure release, manual handling, toxicity, fire and explosion*

5.2.1 All thermal spray operations involve the use of compressed gases, even if only to the extent of using them as a carrier medium for powder. With the exception of acetylene, gases are supplied at pressures up to 300 bar. The uncontrolled release of gases at such pressures can lead to injuries of the eyes, injection of gas into the blood stream and damage to hearing. The use of regulators or other equipment not rated for the service pressure can lead to catastrophic failure of these items. Fatal accidents are possible in these circumstances.

- 5.2.2 The manipulation of the containers of compressed gases and cryogenic gases can give rise to manual handling injuries. Cylinders of compressed gas can become rocket propelled if they are knocked over with the regulator fitted and the main valve open - it is said that a full cylinder can accelerate from 0 to 34 mph in a tenth of a second. Since they weigh 60 kg or more, measures must be taken to avoid this.
- 5.2.3 Many gases have inherently dangerous properties, which are outlined below. The fuel gases are in the main extremely flammable, and are capable of forming explosive mixtures with air. The Dangerous Substances and Explosive Atmospheres Regulations (DSEAR)¹¹ require that a risk assessment shall take into consideration the dangerous properties of materials that can lead to fire and/or explosion, and that measures shall be taken including, where appropriate, hazardous area classification to reduce these risks. The Regulatory Reform Fire Safety Order 2005¹², which replaced the Fire Precautions Act, mirrors these requirements. The 'carrier' gases are generally inert - for instance argon, but the build up of such a gas in a poorly ventilated area can lead to oxygen depletion and a risk of asphyxiation.
- 5.2.4 **Acetylene** is classed as an explosive at pressures above 0.62 bar, and the maximum pipeline working pressure for this gas is 1.5 bar. As little as 2.5% in air will burn. It smells a little like garlic, is lighter than air, and tends to collect in roof spaces. Mechanical shock to the cylinder, or overheating, may cause decomposition within the cylinder, which may result in high temperatures inside, and possible detonation, see also section 6.6.
- 5.2.5 **Hydrogen** is colourless, odourless and non-toxic. It is lighter than air, so may collect in roof spaces. The flame from hydrogen burning in air is difficult to see. As little as 4% hydrogen in air will burn; it is an explosion hazard, and extremely flammable.
- 5.2.6 **'Inert' gases - e.g. helium, nitrogen, argon**
The 'inert' gases used in thermal spraying, such as helium, nitrogen and argon, are non-toxic. However, in quantities sufficient to displace a significant volume of air, they present an asphyxiation hazard.
- 5.2.7 **LPG, e.g. propane**
These gases are often deliberately odourised. They are non-toxic, but gases such as propane are extremely flammable. LPG and propane are heavier than air, and can collect in drains and trenches. They are a potential fire and explosion hazard and are asphyxiants. As little as 2% in air will burn.

5.2.8 **Oxygen**, while being fundamental for survival, is dangerous if present to excess. In an oxygen-enriched atmosphere materials burn very fiercely, to the extent that such fires are extremely difficult to extinguish. Oils and greases can react violently or spontaneously explode on contact with pure oxygen. Most metals, especially in powdered form, will burn in oxygen.

5.3 Noise

Key Hazards: *Stress, difficulty in communication, long term hearing loss, tinnitus*

5.3.1 Exposure to excessive noise can cause stress, difficulty in communication and lack of concentration. The physical effects can include tinnitus, and a progressive loss of hearing due to the damage of the sensory mechanism in the ear. This loss is especially marked in the frequencies that are crucial to the understanding of speech, and thus noise induced hearing loss is a distressing condition. It is permanent, and cannot be helped by hearing aids.

5.3.2 Legislation⁹ now sets three standards by which noise is to be assessed:

Description	Daily or weekly exposure; A-weighted	Peak sound pressure; C-weighted
Lower exposure action value	80 dB	135 dB
Upper exposure action value	85 dB	137 dB
Exposure limit value	87 dB	140 dB

5.3.3 All spraying processes are noisy and may generate noise levels in excess of the lower exposure action values. In particular, the High Velocity Oxy-Fuel Spraying (HVOF) and cold spraying processes emit noise in excess of 130 dB(A) at source. Users of thermal spray equipment are responsible for conducting a risk assessment, which must be based on the exposure of the persons in the workplace, and of which a noise survey is only part. The risk from exposure to noise must be either eliminated at source or reduced to as low a level as is reasonably practicable. If the noise exceeds the upper exposure action value a programme of measures, excluding the provision of personal hearing protectors, is required to reduce the noise to as low a level as is reasonably practicable. Hearing protection is to be provided on request at the lower exposure action values and becomes mandatory at the upper exposure action value. Employers must ensure that their employees are not exposed above the exposure limit value or, if this limit is exceeded, they must take remedial measures to prevent it from happening again. The regulations also specify requirements for demarcation of hearing protection zones, health surveillance and the provision of information, instruction and training. See section 6.8 for more detail about noise control measures.

5.4 Radiant Energy

Key Hazards: Cataract, burns, arc-eye

5.4.1 The flame spray processes emit light within the visible and infrared regions. Exposure to excessive radiation in these regions over a long period of time can cause cataracts.

5.4.2 The arc and plasma processes emit quantities of ultraviolet light, in addition to visible and infrared radiation. Ultraviolet light can give rise to arc-eye and skin burns. See section 6.8 for further information about controlling the risks from radiant energy.

5.5 Fume and Dust

Key Hazards: Fire and explosion, toxic effects by inhalation, toxic effects by skin contact

5.5.1 Powdered metals, particularly titanium, aluminium and magnesium, give rise to a fire and explosion risk, depending on the circumstances. Powdered materials can collect in ducting, on filters and around the spray booth. If these accumulations are heavy, and they are disturbed, they can be ignited.

5.5.2 An explosion may result from the ignition of a dust cloud inside or outside the equipment. A fire may follow from an explosion and its fireball, or may result from self-ignition of layers of accumulated dust on hot surfaces, including some electrical equipment. Where this is a risk, the employer must carry out the risk assessment specified by DSEAR¹¹ and the Regulatory Reform (Fire Safety) Order.¹²

5.5.3 Many of the materials that are routinely sprayed have the potential to be hazardous to health due to their intrinsic properties. Even the least toxic materials, if present in the air in sufficient quantity, can be hazardous to health. Powders for spraying are frequently supplied in size ranges that can be inhaled, and the spray processes all produce airborne particulate matter in size ranges that can be inhaled. Both inhalable and respirable matter may be produced. Respirable particles are more hazardous because they can be breathed deeply into the lungs.

5.5.4 The user must therefore identify the hazards, assess the risks and prevent or, where not reasonably practicable, adequately control them in accordance with the requirements of the Control of Substances Hazardous to Health Regulations (COSHH).¹⁰ This assessment must take into account all occasions where exposure may occur - which include loading the hoppers, spraying, cleaning, disposal and maintenance.

5.5.5 Several commonly sprayed substances are subject to statutory exposure limits, which are listed and updated annually in the Health and Safety Executive's publication Occupational Exposure Limits, EH40.¹⁵

Workplace Exposure Limits (2007) (units mg m⁻³)

Note: these limits can change - always check with the most recent EH40.

Aluminium oxide	Chromium (III) compounds, e.g. chromium oxide, chromium carbide	Chromium (VI) compounds	Cobalt (and Compounds)	Copper	Iron oxide
10 (total) 4 (respirable)	0.5	0.05	0.1	0.2 (fume) 1.0 (dusts)	5

Molybdenum compounds	Nickel and compounds	Tin compounds	Titanium dioxide	Tungsten and compounds	Zinc oxide
5 (soluble) 10 (insoluble)	0.1 (soluble) 0.5 (insoluble)	2	10 (total) 4 (respirable)	1 (soluble) 5 (insoluble)	5

5.5.6 The first requirement is to prevent exposure by substitution or by complete enclosure. Control of exposure is not deemed to be adequate unless the eight general principles of good practice set out in Schedule 2A to the Regulations have been applied, and any defined Workplace Exposure Limit has not been exceeded. In addition, exposure to substances that:

- carry risk phrases R45,R46 or R49, or
- are specified in Schedule 1, or
- have risk phrases R42 or R42/43, or
- are listed in the HSE publication 'Asthmagen? Critical assessments of the evidence for agents implicated in occupational asthma,¹⁶

must be reduced to as low a level as is reasonably practicable.

5.5.8 Aluminium

Long term inhalation of aluminium powder or aluminium oxide may cause scarring of the lungs. Aluminium powder is highly flammable, can form explosive mixtures with air, and reacts with water to form hydrogen.

5.5.9 Chromium

Prolonged exposure to chromium metal dust may give rise to lung fibrosis. It is highly toxic. Chromium oxide and chromium carbide feedstock are both chromium (III), the less toxic form of chromium, however spraying may convert chromium (III) compounds to chromium (VI) compounds, which are suspected human carcinogens, and would normally carry risk phrases R45 or R49. Chromium (VI) compounds are also capable of causing sensitisation. Exposure to chromium (VI) compounds must therefore be reduced to as low a level as is reasonably practicable.

5.5.10 **Cobalt**

Cobalt is moderately toxic. Cobalt and its compounds may cause sensitisation by inhalation and skin contact, resulting in occupational asthma and allergic dermatitis, and hence exposure must be reduced to as low a level as is reasonably practicable. Cobalt powder is highly flammable.

5.5.11 **Copper**

Copper fume may give rise to metal fume fever. Inhalation may cause muscle weakness and headache. Some compounds of copper are highly toxic and may cause long term effects.

5.5.12 **Iron**

Inhalation of iron oxides over a long period may cause scarring of the lungs without physiological symptoms. Iron powder is highly flammable.

5.5.13 **Molybdenum**

Occupational ill-health from exposure to molybdenum is unlikely. It is highly flammable.

5.5.14 **Nickel**

Nickel is harmful. Repeated skin contact may cause allergic contact dermatitis. Some of its compounds are suspected human carcinogens, and exposure must be reduced to as low a level as is reasonably practicable. The powder is highly flammable.

5.5.15 **Tin**

Tin powder may cause irritation. Inhalation over a long period may cause scarring of the lungs without physiological symptoms. It is highly flammable.

5.5.16 **Titanium**

Occupational ill-health from exposure to titanium is unlikely. Titanium powder is highly flammable.

5.5.17 **Tungsten**

Ingestion of soluble tungsten compounds may cause illness but occupational ingestion of tungsten other than in hard-metal alloy is not known to cause long-term ill health. The powder is highly flammable.

5.5.18 **Zinc**

Zinc can cause metal fume fever, but is otherwise only moderately toxic. The dust is highly flammable, pyrophoric, and can form explosive mixtures with air. In addition, it can react with water to form hydrogen.

5.6 Combustion Products

5.6.1 All combustion processes i.e. flame and high velocity oxy fuel spraying produce combustion products⁶⁶ including CO₂, CO and H₂O Due to the high volumes of gases used in some processes e.g. HVOF these combustion products can accumulate very quickly, particularly where extraction is inadequate. Therefore, there is a significant risk of carbon monoxide poisoning when using these processes.

5.7 Water-Borne Diseases

Key Hazard: *Legionellosis*

5.7.1 If a wet collector is installed to capture the over-sprayed material, it is likely to become contaminated with the particulate matter in the over spray. For at least part of the year, the temperature of the water in the UK will be within the range where bacteria grow freely, with ideal growing conditions provided by the particulate matter. Therefore there is a risk of colonisation by bacteria, including legionella pneumophila.¹⁷

5.7.2 During the spraying process the wet collector has the potential to produce airborne droplets, which may remain within the spray booth, or be carried out with the extracted air from the booth. This may expose the operators, other workers, and members of the public to legionellosis, including Legionnaire's disease, a type of pneumonia that can be fatal.

5.8 Mechanical Hazards

Key Hazards: *Entanglement, being struck by machinery, trips and falls*

5.8.1 If equipment has been installed to manipulate the component and/or spray gun, it is important that it is designed to protect the operator from mechanical hazards. It is possible for the operator to be struck by a moving table or manipulator, to be crushed against the wall of the booth, or to become entangled in rotating machinery. Serious injury could result.5.8.2 In the relatively confined area of a spray booth, trailing cables and other obstructions present a tripping hazard, and because of the close proximity to machinery, the consequences may be serious.

5.9 Electricity

Key Hazards: *Electric shock, explosion, fire, burns*

5.9.1 Electricity can give rise to electric shock, fire, explosions and burns. It can also lead to falls or muscular injury. The risk of death from electric shock is related to the current that passes through the body, and the path that it takes. Voltages below 50V ac or 120V dc are considered safe except in conducting environments. A typical spray booth is a conducting environment. However, the power supply for the equipment will usually be fed from a higher voltage supply, typically 240 or 415 V, which must always be considered to be hazardous.

5.9.2 Other related causes of electrical accidents include poor placement of cables. They may become trapped in booth doors, or damaged while they are on the floor, leading to exposure of the live conductors. Electrical apparatus can also be the source of sparks and, like electrostatic discharges, can ignite explosive mixtures, additionally they can cause a fire which, with the gases present, could be dangerous.

5.10 Cryogenic Gases

Key Hazards: Asphyxiation, burns

5.10.1 Gases from cylinders or from cryogenic stores can build up in relatively confined spaces, giving an asphyxiation hazard due to oxygen depletion. It is important to judge whether a gas stored in such a space could do this by calculation of the volume. Fatal accidents have occurred from such causes. Cryogenic liquids, such as liquid nitrogen can also give rise to severe cold burns. If liquid nitrogen is decanted from one container to another through a pipe, the liquid that forms on the outside of the pipe, and runs off it, is very rich in oxygen. This can pose a fire hazard, particularly if the liquid soaks into clothing.

5.11 A Summary Table of the Key Hazards Present in the Main Spraying Processes

5.11.1 In the table below, a very approximate rating of the hazards in typical circumstances has been given. The references are to the installation stage, section 6, and the operation stage, section 7. It must be stressed that the hazard ratings may change in individual circumstances, for example the rating for toxic consumables would relate directly to the consumable in use.

Hazard	Flame Spray	Arc Spray	Plasma Spray in Air	Plasma Spray in Vacuum	HVOF	Cold Spraying	Paragraph No.
Compressed Gases	*	*	*	*	*	*	6.2 to 6.7, 7.2
Combustion Products	*				*		
Highly flammable or extremely flammable gases, hydrogen, propane, acetylene, LPG and/or oxygen (fire and explosion risk)	*		*** Hydrogen	***	***		6.2 to 6.7, 7.2
Asphyxiant gases	*	*	*	*	*	*	6.6, 7.2
Combustion products	*				***		
Noise	**	**	***	**	***	***	6.8, 7.3
UV radiation		*	**	*			6.8, 7.4
Fine dusts, fume and powders (explosion risk)	* to ***	* to ***	* to ***	* to ***	* to ***	* to ***	6.8, 7.5
Potentially toxic consumables	* to ***	* to ***	* to ***	* to ***	* to ***	* to ***	6.8, 7.5
Water borne disease	*	*	*		*	*	6.9
Mechanical hazards (automated equipment)	*	*	*	*	*	*	6.10, 7.6
Electric shock	*	*	*	*	*	*	6.11, 7.7
Cryogenic gases (where used)			*		*		

The more stars, the greater the severity of the hazard highlighted for this process.

*** very high hazard

** medium level of hazard

* lower level of hazard

6. Design, construction and installation of equipment

6.1 Introduction

6.1.1 At the outset, the user of the equipment should conduct a risk assessment to ensure that the equipment will be sited in a suitable area, and that as many hazards as is reasonably practicable are avoided. Those that remain should be controlled by engineering means if feasible, and this will form a large element in the design, construction and installation of the equipment. The user must also consider all phases of the life cycle of the equipment - the design, construction, installation, commissioning, use, maintenance, repair and decommissioning/disposal.

6.2 Hazardous Area Classification

Definition of Terms¹⁸

6.2.1 **Hazardous area:** An area in which an explosive gas atmosphere is present, or may be expected to be present, in quantities such as to require special precautions for the construction, installation and use of apparatus. Hazardous areas are classified into one of three zones, 0, 1 and 2, depending on the frequency and duration of an explosive gas atmosphere occurring.

6.2.2 **Zone 0:** An area in which an explosive gas atmosphere is present continuously or for long periods (this is defined as more than 1000 hours per year). *Example: At the spray gun tip before/after ignition or when the flame goes out.*

6.2.3 **Zone 1:** An area in which an explosive gas atmosphere is likely to occur in normal operation (this is defined as less than 1000 hours, but more than 10 hours per year). *Example: Inside the spray booth. The immediate area around the flammable gas stores.*

6.2.4 **Zone 2:** An area in which an explosive gas atmosphere is not likely to occur in normal operation and, if it does occur, is likely to do so only infrequently and will exist for a short period only (this is defined as less than 10 hours per year). *Example: The area around a flange, connection or other pipe fitting that is not expected to release flammable material during normal operation.*

6.2.5 Any thermal spray/metal deposition process that uses liquid or gaseous fuel will have the potential to generate a flammable/explosive atmosphere. Manufacturers of equipment have a legal obligation to ensure that their equipment is built to safe standards. Gas suppliers are equally obliged to ensure that their products and equipment are supplied safe for use. Users of this type of equipment have a responsibility to ensure that it is safely installed within their premises in order to minimise the potential for explosion, and thereafter used and maintained in a

safe condition. Explosions can also arise from the dusts generated in thermal spraying processes.

- 6.2.6 Users must therefore assess their installations to determine whether there are potential sources of release of flammable/explosive materials, e.g. from joints in pipework, valves, connections, fittings, etc, in accordance with the requirements of DSEAR¹¹ and the Regulatory Reform (Fire Safety) Order¹². Any part of the equipment that contains mechanical joints as opposed to welded joints will eventually leak. The recommended method for doing this assessment is called "Hazardous Area Classification" (HAC). HAC helps the user to locate the equipment appropriately and determines, by a system of zoning, the separation required from other potentially hazardous activities, and the equipment that may be safely used in the area. Zones should be clearly defined with appropriate signs, etc.
- 6.2.7 In general, HAC will be required wherever liquid or gaseous fuels are used in fixed installations. The European Standard BS EN 60079-10: 1996, "Electrical apparatus for explosive gas atmospheres, Part 10. Classification of hazardous areas" is the applicable standard.¹⁸ Both electrical and non-electrical sources of ignition should be considered as part of the overall assessment process. BS EN 60079-10: 1996 defines certain key terms, which are to be found in the section on definition of terms, and reiterated at the start of this section.
- 6.2.8 The zone designation determines the standards to which apparatus used in the various zones must conform. For existing installations this requirement will be retrospective and must be strictly applied.
- 6.2.9 Dusts can also create an explosion hazard, and BS EN 50281¹⁹ relates to hazardous area classification for these materials.
- 6.2.10 Hazardous area classification is a time consuming and specialised process. It requires a multi-disciplinary team led by someone fully trained and competent in hazardous area classification. Specialist help may be required.
- 6.2.11 It should be stressed that HAC is only part of the risk assessment process that is required to design and install thermal spray equipment.

6.3 The Spray Equipment

- 6.3.1 New equipment supplied for use in Europe, must have a CE mark and a Declaration of Conformity, or a Declaration of Incorporation²⁰ stating compliance with the various Directives. Used equipment older than the date of CE introductions is exempt so long as it is not modified in any way. To justify CE marking the equipment, the manufacturer will have to ensure that it has been designed with safety in mind, according to either generic or specific standards, e.g. references²¹⁻²⁹. The

manufacturer's declaration will indicate to which European Directives the equipment conforms. These will include the Machinery Directive, the Low Voltage Directive, the Electromagnetic Compatibility Directive and the ATEX Directive (Explosive Atmospheres Directive). *Note that a manufacturer's declaration is not a guarantee of safety, but it is an indication that he has done a risk analysis on the product which can be reviewed by the authorities (not by potential or existing customers). Nevertheless, the responsibility for safety lies with the user.* (Gas equipment does not yet fall within the scope of CE marking.)

- 6.3.2 Manufacturers of thermal spraying equipment have a legal duty to ensure that the equipment they supply is safe for its intended use. This will include compliance with the 'Equipment and Protective Systems Intended for Use in Potentially Explosive Atmospheres Regulations 1996'³⁰ which implements the requirements of the ATEX Directive from June 2003. Some parts of the equipment will not be able to conform to the ATEX Directive, because of the flame or arc being present. Ultimately the design standards to be applied will be determined, where relevant, by the Hazardous Area Classification (HAC). It is important that users consult with manufacturers at the earliest opportunity to determine the recommended conditions of installation, including the location.
- 6.3.3 A major consideration in all but the arc spray process is the safe handling of flammable gases. The spray area must be designed and installed so as to avoid so far as is reasonably practicable the possibility that an explosive or flammable mixture will exist in the workplace. Measures should also be taken to minimise the possibility of the ignition of such a mixture if it did arise due to a failure. The HAC must take into account the hazards already present in the workplace as well as those brought in by spraying equipment. It is important that a suitable and sufficient fire risk assessment is conducted.^{11, 12, 31}
- 6.3.4 The HAC will enable the user to zone the work area, to define the engineering controls that are necessary, and the activities and ancillary equipment that are to be permitted in each part of the work area. Potential sources of ignition in the area could include the spray equipment, uncertified electrical equipment, defective or poorly maintained electrical equipment, unsafe working practices, electrostatic discharges, hot surfaces and might include operations such as grinding etc.
- 6.3.5 Only competent, suitably qualified/trained personnel should install thermal spray equipment. Users will generally be buying equipment from more than one source, and if this is the case they take the responsibility for safely integrating the items into a whole. This must be incorporated into their risk assessment. They need to satisfy themselves that they have obtained sufficient information from the suppliers of the major

components of the system (e.g. the spray equipment, booth manufacturer, extraction system manufacturer), that it can all be integrated to form a safe piece of equipment, with adequate safeguard against mechanical and operator failure. The user should ensure that all aspects of the installation conform to the Provision and Use of Work Equipment Regulations.⁵

6.4 Location of Thermal Spraying Equipment

- 6.4.1 Spraying equipment must not create hazards for nearby processes nor must it be put at risk by nearby processes. It should be located against an outside wall to facilitate easy gas delivery. This will also make the installation of the ventilation and extraction easier. The building should be single storey, to avoid gas accumulating in occupied or at-risk areas above or below the process.
- 6.4.2 The location should be free from unventilated areas overhead, such as voids above false ceilings where lighter than air gases could accumulate; and from voids below floor level, such as pits, service trenches, gullies or underground rooms, where gases that are heavier than air could accumulate.
- 6.4.3 The area should be as spacious as possible, with a high ceiling and good natural ventilation. There should be plenty of air inlets, roof vents and opening doors and windows. The design ventilation rate, for example five volume changes of air per hour needs to be specified. Five volume changes can normally be obtained by ensuring that 2 to 3% of the wall and roof area is ventilated, distributed between high and low level. Mechanical ventilation may need to draw from low level for heavier than air gases (such as LPG and propane, argon).



*Figure 6: A spray booth set up inside an existing workshop
(Picture courtesy TWI)*

6.4.4 The HAC will determine the allowable proximity of sources of ignition. Possible sources would include machinery, ovens, furnaces, boilers, heaters, and operations such as grinding, cutting, welding, etc. The HAC will determine the extent of the area that should be free of any electrical equipment, e.g. wall sockets, isolator boxes, junction boxes, control panels, which have not been designed for use in the classified areas.

6.5 Gas Storage

6.5.1 It is advised that, wherever possible, the stores for bulk supply of gases are outside the work area, in purpose-built bays that can be locked. For thermal spraying, gases may be purchased as single cylinders, manifolded cylinder banks or as cryogenic liquid vessels. Access should be designed with care, since the gas cylinders will be delivered to the site from lorries, and the gases will be probably be removed from the store either using fork lift trucks (if they are in banks) or using trolleys if single gas cylinders.

6.5.2 Fuel gases and oxygen must be segregated, either by a distance of not less than three metres, or by a wall that can resist fire for a minimum of 30 minutes. It is permissible to keep LPG and propane with acetylene provided that the quantity of LPG and propane does not exceed 50 kg, otherwise they must be segregated. Hydrogen must be segregated from other fuel gases by a distance of at least one metre. The store should be well ventilated and, if it is outdoors, the cylinders should be protected against rain and direct sunlight. Storage areas should be kept clean and only used for the storage of cylinders.



*Figure 6: Purpose built stores for oxygen and hydrogen
(Pictures courtesy BOC gases)*

- 6.5.3 Empty gas cylinders should be segregated from full or partially used cylinders. The store must be marked with relevant signs - e.g. 'flammable gas', 'no smoking'. For more details on gas storage see BCGA Guidance Note GN2.³²

6.6 Fuel Delivery to the Spray Equipment High Pressure Gas Equipment

- 6.6.1 The Pressure Systems Safety Regulations³³ stipulate the legal requirements for design, periodic examination, maintenance and repair of gas systems. Gas supply systems should be designed and installed in accordance with BCGA Codes of Practice CP7 for single cylinders³⁴, CP4 for manifold systems³⁵, CP6 for acetylene³⁶ and CP5 for acetylene manifolds.³⁷ Note: the design and construction requirements of transportable pressure receptacles (i.e. gas cylinders) used for the carriage of gas to fixed installations are covered by The Carriage of Dangerous Goods (Classification, Packaging and Labelling) and Use of Transportable Pressure Receptacles Regulations.³⁸
- 6.6.2 Acetylene is subject to specific legislation, but prior approval is not required for an installation between 0.62 and 1.5 bar, provided that the conditions of Certificate of Exemption No. 2 1989, made under the Explosives Act (Exemption) Regulations³⁹, are complied with. The user should refer to the Health and Safety Executive, Explosives Inspectorate, Bootle, before proceeding.
- 6.6.3 Fixed installations, which may include plasma, high velocity oxy-fuel spray (HVOF), cold spray and automated flame spray will require fixed piping from the gas storage area to the working area and the design of the system has to take into account that sufficient flow is available. It is strongly recommended that the advice of a reputable manufacturer or preferably a gas supplier is taken in the design of this system, since adequate provision must be made for the protection of the system against such faults as flashback, by the inclusion of flashback arrestors and non-return valves. The use of flexible piping should be kept to a minimum.
- 6.6.4 The design and integrity of the gas delivery system, taken in conjunction with control measures, such as gas detection and interlocking of the thermal spray equipment, forms a crucial part of the HAC. It is advised that competent advice is sought.
- 6.6.5 Manifolds and piped systems should be installed in accordance with the relevant BCGA codes of practice by competent installers who have been trained in the hazards of the gases being used. Care should be taken in the routing of gases. Pipework should be routed on the outside of the building for as much of its run as is reasonably practicable. The pipework should have the minimum number of connections, in order to minimise possible sources of leaks. Once pipework enters the building it should be a single section of pipe until it connects

with the process. If this is not practicable then all necessary connections must either be welded or brazed to eliminate/minimise potential sources of leaks within the building. Soft soldered joints are not acceptable.³⁶

- 6.6.6 The systems should be installed using solid pipework as far as possible; the use of rubber hoses, even to the appropriate standard, should be limited to reduce the risk of damage and gas leaks. The pipework should be visible and accessible for inspection and maintenance purposes hence installation in ducts, roof spaces and enclosed spaces should be avoided. All pipework should be suitably marked, indicating the type of gas within the system and its direction of flow.
- 6.6.7 Once installation is complete, the system shall be visually inspected by a competent person and pressure tested. The pressure test should be carried out at 1.5 times its maximum working pressure using an inert gas with similar properties to the fuel gas used in the system (e.g. helium can be used to test a hydrogen system). The pressure should be held in the system for a period not less than 30 minutes without a drop. The competent person should issue an appropriate certificate of testing. Appropriate safety precautions should be taken during gas testing, see Health and Safety Executive guidance note GS4.⁴⁰
- 6.6.8 Equipment for use with oxygen must be certified as clean for oxygen service. It is essential to ensure that no organic materials such as oils or greases come into contact with oxygen, otherwise a fire or explosion may result.
- 6.6.9 The hazardous area classification must be carried out on an oxy-fuel installation to identify the areas that need zoning.

Low Pressure Gas Equipment

- 6.6.10 Flexible hoses for low pressure delivery to equipment (less than 20 bar) should be correctly colour coded, and manufactured to the correct specifications (BS EN 559, 2003⁴¹ or equivalent ISO or DIN standard):

Acetylene, hydrogen	Red
Propane and LPG	Orange
Oxygen	Blue
Non-combustible gases	Black

- 6.6.11 Connections should be by means of crimp type, non-adjusting hose clips.⁴² Pieces of twisted wire, or the screwdriver adjustable bands should not be used.

Kerosene

- 6.6.12 For systems fuelled by kerosene, the possibility of producing an explosive mixture is much reduced, since the flash point of kerosene is higher than fuels such as acetylene or propane (the

precise temperature depends on the kerosene type). However, an atomised spray could explode. The fuel may be fed by a pressurised line to the console, leakage from which could therefore create a risk of explosion. Thus on the high pressure side an all-metal pipe should be fitted. A metal-braided hydraulic hose should be used to connect the console to the gun.

6.7 Gas Detection

- 6.7.1 There is the potential for gas leaks to occur, even in the best installed and maintained plant. Small leaks may be dispersed by an adequate general ventilation system. If a large leak should occur, greater than the capacity of the ventilation system, it is important that the leak is detected quickly, so that the fuel gas can be isolated and the equipment shut down safely.
- 6.7.2 Gas detection will not prevent gas releases, but will detect them before they reach explosive levels, and detection systems can be connected to initiate gas shut-off, isolation of electrical supply and can be used either to maintain ventilation or to activate emergency ventilation systems. Gas detection relies on accurate calibration, appropriate positioning and regular inspection and testing for its effectiveness - advice on this and on the type of gas detector required will be given by the supplier. It is important that everyone involved with this type of equipment fully understands the purpose of gas detection and what to do if it alarms. Complacency must be guarded against.
- 6.7.3 The decision to install gas detection should be based on a suitable and sufficient risk assessment, taking account of the existing controls, age, condition and layout of the process. This will require advice and assistance from a safety practitioner, and possibly a supplier of gas detection equipment. The places most likely to require gas detection will be confined spaces on processes where there is a potential for creating an explosive gas atmosphere. Some manufacturers of metal spray equipment now fit gas detection within spray booths and control panels as standard. However, for existing equipment the necessity for gas detection needs to be evaluated against the adequacy of the ventilation levels achieved in these areas - a suitable and sufficient risk assessment will help to determine this.
- 6.7.4 If gas detection is deemed necessary, it is vital that it is interlocked to the ventilation system and the gas and electricity supplies. This is so that:
- On start-up of the equipment, the interlocked system will not allow the fuel supply to be opened until the ventilation system has removed any flammable gas and is fully operational.
 - If the ventilation system fails, then the gas and electricity supplies are isolated .

- No-one is allowed to enter the room until the ventilation system has removed any flammable gas and it is fully operational.

In the event of an alarm, the following should all happen simultaneously:

- The electricity supply is isolated, to prevent ignition sources
- The ventilation system continues to operate and/or an emergency ventilation system is activated, to provide increased levels of ventilation
- The fuel gas supply is rapidly shut off at source.

The integrity of the electrical systems should be appropriate for the risks involved.^{25,29}

6.8 Enclosure

6.8.1 Many thermal spray installations are installed in permanent enclosures. The enclosure will house the spray gun itself, the manipulation system(s) for the components and/or gun and any cooling system for the components. It will also contain the equipment for the removal of overspray and fume and dust. The control console should be sited outside the enclosure, so that the operator is not exposed to the hazards within. The powder hopper should be outside the enclosure if possible, but may be sited inside.

6.8.2 Any extraction system fitted to the enclosure should not be disabled or shut down by the equipment 'emergency stop'. In addition, the extraction system should be interlocked with the spray equipment in order that the operation of the spray equipment is disabled if the extraction system fails, or is not running.

Protection From Noise

6.8.3 Plasma, high velocity oxy-fuel spray (HVOF) and cold systems are usually installed in purpose-built enclosures, designed to control the exposure of the operator and others to noise.

6.8.4 In controlling exposure to noise, the first priority is to choose equipment that is less noisy, and thus to solve the problem at source.⁹ Good design is also important; designing out noise should be considered by manufacturers. Where this is not practicable, the noisy equipment should be installed in a sound attenuated booth designed to reduce the noise levels to below 80 dB(A). If enclosures are to be built around equipment for safety and containment purposes, consideration should be given to their acoustic properties and where possible they should be used as acoustic enclosures.

6.8.5 If noise levels associated with the operation of the equipment cannot be brought down below 80 dB(A), further measures must be taken. If employees and others are liable to be exposed to a daily personal noise exposure of 80 dB(A), or more, The Control of Noise at Work Regulations⁹ require the employer to

carry out an assessment of the employees' (and any others who may be affected) exposure to noise. The results of this assessment will show what further measures must be taken. The exposure action values and limit values are tabulated in section 5.3.

- 6.8.6 In particular, any area where an employee is likely to be exposed at or above the upper exposure action value of 85 dB(A) is designated a hearing protection zone where ear protection must be worn. The requirement for personal protective equipment is described in the Personal Protective Equipment Regulations.⁴³

Protection From Fume, Dust and Combustion products

- 6.8.7 The hierarchy for control of exposure to dust, fume and combustion products is first to enclose the process, but if this is not reasonably practicable, to extract it, and as a last resort to issue personal protective equipment, in accordance with the Regulations.⁴³ Workplace exposure limits must be met, and where there are substances that are potential sensitisers or carcinogens the exposure must be reduced to the lowest level reasonably practicable.
- 6.8.8 Since the operator will need to enter the enclosure, it must be fitted with an extraction system to remove dust, gas and fume. The extraction system should be interlocked with the thermal spray equipment to ensure that if the system is not operational then the gun cannot run. The flow rate for extraction must be adequate to ensure that exposure of the operators is controlled according to the requirements of the Control of Substances Hazardous to Health Regulations.¹⁰
- 6.8.9 In general, where the spray process is operated within an enclosure, with the operator situated outside, the extraction system will reduce the exposure of the operator to fume, dust and combustion products to a low level, provided he or she remains outside.
- 6.8.10 Entering the booth could potentially lead to exposure to fume, dust and combustion products and for this reason consideration should be given to designing the system so that the operator is not able to enter until some time has elapsed from the end of spraying operations. This will allow the extraction system to clear the fume, dust and combustion products from the atmosphere. However efficient the air extraction equipment may be, operators who enter the enclosure during setting up or spraying operations must wear personal protective equipment, which may include clean-air fed respirators, if conditions warrant it.
- 6.8.11 The exposure of the operator must also be controlled while undertaking such operations as filling the powder hopper.

Dry Extraction Systems

- 6.8.12 Dry extraction systems were originally brought into use in the form of multi cell cyclones but these, due to their design, only effectively capture dust down to around 5 μm . Since a large amount of the particulate released during spraying is below this level this material passes straight through the cyclone.
- 6.8.13 The most common form of dry collector used in thermal spraying today is the dry cartridge filter. This comprises of a series of filter elements folded to form a pleated material and provides the filter area required for the correct filtration of the process. The cartridges are housed within a steel casing mounted, preferably, outside the building. Cleaning of the filters is carried out by reverse pulsing of the cartridges with compressed air. This is a totally automated process carried out whilst spraying is in operation with no operator intervention required. Note that a fire trap, a box with baffle on the booth side, is required where sparks or hot metal may be a problem, e.g. in arc spray, to prevent hot particles getting into the filter. With reactive metals e.g. titanium or aluminium powder, where there is a risk of water contamination, there is risk of explosion and or fire due to the build of H_2 which may form from the reaction of these metals with water.
- 6.8.14 Capture of the particulate can then be carried out in a variety of different methods from a basic hood behind the gun to a more technically advanced 'floorwash' system providing a much higher level of cleanliness and dust collection in the booth. This type of system provides more space for spraying within a current booth or a smaller area used within the factory.
- 6.8.15 The method of filtration, the filter speed and cleaning of the cartridges are all dependent upon the spray process being undertaken and the run times required for the process.

Explosion Risks

- 6.8.16 The filters used in a dry extraction system should be fitted with suitably designed explosion relief panels to vent a pressure build up should it occur. These should vent to a safe place. It should be noted that most dry cartridge filters will only operate up to 60°C, which limits their usage.
- 6.8.17 Where metal dusts, such as titanium and aluminium are present, the fire risks are considerable. These may increase with the cold spray process due to the finer powders employed and also the fact that no oxidation of the powder has occurred during spraying leaving the powder in a highly reactive state. MCrAlY dusts can also catch fire, especially in VPS systems if insufficient ventilation is available before the loading door is opened. The installation should have smooth-walled, round-sectioned ducting with no dead spots where dust can accumulate, short run lengths and preferably only one or two machines to each collector and access points for cleaning and

inspection. Dust collectors should normally be outside, as there is no safe place inside for the opening of an explosion vent.

- 6.8.18 Special techniques should be used when tackling metal fires, for example do not use water. Dry sand and long shovels or special extinguishers i.e. slow release powder extinguishers, should be used. No one should tackle a metal fire unless they have been trained to do so.

Control of Emissions to Atmosphere

- 6.8.19 The vent to the extraction system will generally be outside the building, and filtration will be required to remove the particulate matter from the exhausted air before it is released. There are limits on the particulate content of the exhaust air laid down in Environmental Legislation, summarised in the table below. For further information on the control of emissions, reference should be made to the Secretary of State's Guidance.⁴⁴

Emission limits⁴⁴ (units mg m⁻³)

Total particulate	Chromium	Nickel	Copper	Cobalt
50	15	15	7.5	3

Protection From Radiation

- 6.8.20 To shield operators from ultraviolet, infrared and intense visible light in the plasma and arc spray processes, the windows in the booth should be glazed with suitable filtering material. There is a standard for semi-transparent welding screens that may be appropriate to this application, BS EN 1598.⁴⁵ See references ⁴⁶⁻⁴⁸ for further guidance on controlling the risks from radiant energy.

6.9 Wet Extraction

- 6.9.1 The material that fails to hit the component and stick to it may be collected by a wet collector. Some wet wash systems are unable to adequately abate the emissions produced during thermal spray processes, although there are new types that may be as effective as dry collection.
- 6.9.2 Installation of a wet extraction system must take into account the possible risk from legionellosis, and the engineering control measures that may reduce the risk, such as suppression of the formation of droplets, and the siting of the outlet from the extraction system.¹⁷
- 6.9.3 The water wash is run in addition to an air extraction system from the booth, and it is important to ensure that the air speed is not greater than 9 m s⁻¹, to avoid the entrainment of water droplets into the air extract.

6.10 Machinery in the Booth

- 6.10.1 In operations carried out in an enclosure, machinery to manipulate the gun and/or the component will be installed. This is basically of four types:
- Slow speed traverse
 - High speed traverse
 - Rotating tables or lathes
 - Robot.
- 6.10.2 Measures will need to be taken to prevent machinery that is capable of rapid movement from hitting the operator. High speed traverse systems are fitted with a barrier which is interlocked. The operator sets the 'stop' points with the equipment running slowly.
- 6.10.3 If a robot is installed it is essential that it has hardware stops to limit its movement where the enclosure is smaller than its potential range, or where there are objects within range that it must not reach. Software stops are not sufficient to do this, since they may fail. The equipment should be interlocked such that the robot is disabled if the door is opened. Provision for 'teaching' the robot must be in accordance with the guidance. The user is referred to the Health and Safety Executive guidance on Robots, HSG 43.⁴⁹
- 6.10.4 Spray diagnostic equipment may utilise lasers and the risks associated with them should be taken in to consideration where they are used.

6.11 Electrical Safety

- 6.11.1 All equipment should be connected to the supply in the building by a competent electrician to ensure the integrity and capability of the wiring. Wiring should conform to the requirements for electrical installations in BS 7671.⁵⁰
- 6.11.2 Electrical apparatus is a prime source of ignition of explosive atmospheres. In locations where the zone classification indicates a flammable atmosphere could exist, suitably certified equipment should be employed, see EN 60079-14^{51, 52}, EN 50281-1-2.¹⁹ The extraction equipment for the enclosure should also be appropriately approved.
- 6.11.3 For spraying any metal, e.g. zinc, titanium and aluminium, the risk assessment may show that the equipment needs to be ingress protected (IP) to a specific standard.⁵³ The BS EN 50281¹⁹ is a standard applicable to electrical equipment for use in dust laden atmospheres.
- 6.11.4 Cables should always be placed in a safe position, to avoid trip hazards, damage and being trapped in doors. All conductors should be suitably protected from identifiable mechanical damage.

6.11.5 For all control systems, an appropriate level of integrity, determined from the risk assessment, should be provided. This includes the use of safety related equipment, e.g. interlock switches. For non-software applications refer to BS EN 954²⁹ and for software applications to BS EN 61508⁵⁴.

7. Operational Stage

7.1 Training

7.1.1 Only those who have been thoroughly trained and shown themselves competent should be permitted to operate thermal spray equipment. The more complicated the equipment, the more extensive is the training required before it is reasonable to leave the operator to work without supervision. Standard BS EN ISO 14918 'Approval testing of thermal sprayers'⁵⁵ is primarily concerned with the quality of the coatings produced, and has relatively little on the subject of safety.

7.1.2 The manufacturer's documentation should be made available to the operators, and formal instruction on the material contained in the manuals should be given. All safety recommendations stated in the manufacturer's documentation should be followed.

7.2 Gases

7.2.1 Manifolded cylinder pallets (MCP) of gases will need to be transported and positioned using fork lift trucks. Only trained and appointed fork lift drivers may be permitted to drive these vehicles. They must, in addition, be trained in the handling of manifolded gas cylinders. The HAC will have classified the areas around the gas cylinder store, and access to the fork lift trucks must be controlled. It may be necessary to shut off all the gases, when any are being changed.

7.2.2 Single cylinders should be transported using gas-cylinder trolleys, into which they must be tethered securely. A manual handling risk assessment should be carried out regarding the movement of cylinders, and steps taken to reduce the risk of injury. This should include training in the handling of the loads, should take into account the suitability of the traffic routes that are used to transport cylinders, and the provision of trolleys suited to the location. There is British Compressed Gases Association Guidance available.⁵⁶

7.2.3 Gas cylinders should always be restrained by chains or straps to prevent them from falling, since in so doing they may cause damage to the equipment, operators or others.

7.2.4 It is essential to train the operators in the safe use of compressed gases. It should include as a minimum the procedures for cylinder changing, operator maintenance, equipment operation, cylinder handling and emergency procedures. Gas safety data sheets are available from the gas

supplier, and the information and advice in these sheets should be part of the training of the operators.

- 7.2.5 As a precaution against leaks it is good practice to turn off the gas supplies during times when the equipment is not being used or is unattended, for example each night.

7.3 Noise

7.3.1 A risk assessment must be undertaken where any person is liable to be exposed to the first action level, 80 dB(A), or above. The design and installation of the equipment should have incorporated measures to reduce noise at source and to isolate the operators from high noise exposure, with the aim to bring the likelihood of exposure below the first action level. However, the assessment may indicate that further measures such as the wearing of hearing protection in certain areas may be necessary to control exposure to noise.

7.3.2 Entry into the spray booth while the equipment is running should be avoided wherever possible. If it is essential, then suitable and efficient hearing protection must be worn. Operators of hand held spraying equipment will always require suitable and efficient hearing protection.

7.3.3 It is worth noting that experiments have shown that the actual protection from most ear muffs and plugs is generally much less than quoted by the manufacturers, since people tend not to wear them properly, and will often take them off for short periods, not realising that they are compromising the efficiency of the protective measures. It is important to mount a programme of education on hearing protection, which would include the information that the equipment must be worn at all times where the noise assessment has shown that noise is at dangerous levels. Management should take the lead in setting a good example in the wearing of hearing protection.

7.3.4 Where employees are exposed to noise that is likely to be above the lower exposure action value (80dB(A)) instruction, information and training needs to be given to include:

- the nature of the risks from exposure to noise,
- the measures taken to reduce or eliminate it,
- the exposure limit values and upper and lower exposure action values,
- the significant findings of the risk assessment,
- the availability and provision of personal hearing protectors and their correct use,
- why and how to report signs of hearing damage,
- the entitlement to health surveillance and its purposes
- safe working practices to minimise exposure to noise
- the collective results of any health surveillance.

Training in the use of hearing protection should include how to fit the muffs correctly, and how to inspect and maintain them. Because hearing protection is often not used to its maximum

benefit, it is advised that hearing protection of a slightly higher performance than is apparently required should be purchased.

7.4 Radiation

- 7.4.1 For manual flame spraying operations a face shield is advised. The shade number is related to gas flow rates, and British Standard BS EN 169 should be consulted.⁵⁷
- 7.4.2 Where arc or plasma spraying processes are carried out, it is essential that operators and others are protected from the ultraviolet radiation if the process is not enclosed. Full personal protective equipment is required by the operator, including a visor and clothing to cover all the skin; curtains may be used to shield others from exposure.
- 7.4.3 When these processes are carried out in purpose-built booths, the windows shield the operators and others.

7.5 Fume and Dust

- 7.5.1 In general, where processes are operated within a dedicated booth, the integral control system (e.g. extraction fans and water curtain) should be set up so as to be adequate to control the fume and dust to a safe level. In particular, the extraction system should be started up prior to the spray equipment being activated, to ensure that the air flow is adequate before fume and dusts are generated. Shutting down of the extraction system should be delayed after spraying has ceased and the operator should remain outside the booth until the dust and fume are adequately cleared from it.
- 7.5.2 Problems may arise when undertaking hand-held operation of the spray guns, since then the operator is liable to be exposed to dust and fume. The exposure is liable to affect the eyes, but the protection chosen to shield the face from radiation should control this risk.
- 7.5.3 Exposure to the risk of inhalation of fume and dust must be assessed to comply with the Control of Substances Hazardous to Health Regulations (COSHH)¹⁰, and to determine the measures required to control exposure. In special cases, for instance when spraying a toxic material on site, it may be necessary to use an air fed helmet with tinted visor. The air must be of breathable quality, as set out in BS EN 12021 (formerly covered by BS4275).⁵⁸
- 7.5.4 Powdered materials should be stored in such a way as to prevent their being blown around the workplace. They should be stored dry in covered containers. In the event of spillages, dry sweeping should not be permitted. Note that many powdered metals can constitute a fire or explosion hazard. When cleaning up work areas, employees should avoid dry sweeping up with a broom. Use extraction equipment or suitable vacuum cleaners fitted with high efficiency particulate arrestor (HEPA) filters.

7.5.5 Operators must ensure that the collection bins in any dry extraction system are checked regularly to ensure that they are changed when required. It is essential that the correct personal protective equipment is provided and used in accordance with the COSHH regulations. Collected dusts and the wet dusts from wet collection should be treated as hazardous waste in accordance with the Environmental Protection Act.¹⁴

7.6 Mechanical Hazards

7.6.1 Robots and high speed scan units pose hazards to operators. Adequate interlocking should have been incorporated at the installation stage, and training must be given. Where it is necessary to 'teach' a robot, there must be a secure means of switching it over to the 'teach' mode, in which the speed of the device is limited, so that it cannot be set to run at full speed while the operator is inside the work area. Reference should be made to Health and Safety Executive guidance on robots.⁴⁹

7.6.2 The layout of cabling and mechanical equipment within the booth can contribute a great deal to the avoidance of trips and being trapped or struck by equipment.

7.6.3 Good housekeeping within the spray area can also contribute a great deal to the maintenance of a safe environment.

7.7 Electrical

7.7.1 Plasma and arc spray guns operate with DC electrical power. Some equipment may be at high voltages, and great care should be taken to avoid any contact with live components.

7.7.2 In those processes that required HAC, great care must be taken to avoid the introduction of uncertified electrical equipment into the classified hazardous areas.

8. Modifications

8.1 Modifications to thermal spray equipment should only be performed either by the manufacturer, or by a competent person with the approval of the manufacturer. They must not invalidate equipment certification e.g. HAC and safety integrity levels. Consideration should be given to ensure the continued correct operation of safety and emergency interlocks and any software programs associated with electrical safety. It is essential that they continue to function in an integrated and effective fashion.

8.2 Where reasonably practicable, older equipment should be upgraded to meet the current level of safety standards - to include gas detection, exhaust airflow monitoring, flame detection, robotic guarding, door switches, emergency stop circuits.

8.3 It is particularly important, for the oxy-fuel processes, to assess the effect of any proposed modifications or alterations on the hazardous area classification.

9. Maintenance and repair

9.1 Introduction

- 9.1.1 Maintenance schedules as recommended by the manufacturer should be adhered to. Equipment for the purposes of controlling health and safety risks should be adequately maintained. Before embarking on any maintenance or repair work, a risk assessment should be conducted, to highlight potential hazards and to specify the control measures that should be taken to minimise the associated risks. This may include isolating the gas and electrical supplies to the equipment. The area should be tested to demonstrate that there is no flammable gas present and that the circuits are indeed dead. Training, assessment and re-assessment of the competence of the maintenance or repair personnel is a key element of a safe system of work during maintenance or repair.
- 9.1.2 Maintenance and repair, whether carried out in-house or by contractors must be adequately controlled, including special measures such as permits to work, where appropriate. Users must ensure that contractors are competent and use a safe system of work during such activities.
- 9.1.3 Under normal circumstances, before commencing work, the electrical equipment should be isolated, with the fuses removed and isolators locked off with a padlock (with only one key). Regarding live working, Regulation 14 of the Electricity at Work Regulations 1989¹³ requires that three conditions are met for live working to be permitted where danger may arise. An assessment procedure for deciding whether to work dead or alive can be found in HSE booklet HSG 85 'Electricity at work: safe working practices'.⁵⁹ All live working should be controlled by some form of documentation to confirm that the hazardous area has been de-classified for the duration of testing and how it is to be maintained in that condition. Suitable measures must be taken - to include tools suitable for live working, rubber mats, warning signs, restriction of work to suitably competent persons. It is essential to check for gas leaks before embarking on live electrical work, and to use a gas detector during the work to ensure that the atmosphere remains free from flammable gas. Before using gas detection equipment, ensure its integrity and that it is correctly calibrated and any mechanical ventilation is operating as designed.
- 9.1.4 The maintenance/repair engineer should be protected from the hazards associated with high speed scan units or robots by isolating them and locking them off. This may require a permit to work to ensure that the isolation is secured.
- 9.1.5 Where hot work or otherwise hazardous work is to be carried out, a permit to work system should be implemented to ensure that the safety measures are in place before work starts. The permit to work is used to specify what work is to be done, who

is to do it, what measures have been taken to ensure that the equipment is safe while it is being done. It will lay down the conditions under which the work is to be done, and will entail a formal process for ending the work and returning the equipment to its normal state.

- 9.1.6 Equipment should only be calibrated by suitably qualified personnel to ensure safe and proper operation - see the manufacturer's recommendations.
- 9.1.7 It is essential that any maintenance work should not affect the integrity of the equipment or the hazardous area classification - see BS EN 60079 part 17.⁶⁰ Any components that are replaced should be those manufactured to a standard suited to their application. All maintenance and repair work must not invalidate the electrical equipment certification.

9.2 Gas Systems

- 9.2.1 Full details of the recommended maintenance of pipework systems are in BCGA CP4³⁵, and this includes weekly inspections by the user and annual inspections by a competent person in accordance with the Written Scheme of Examination. Documentation of such checks is required. A written scheme of examination is required under the Pressure System Safety Regulations for all protective devices and for all pressure vessels and parts of the pipework in which a defect may give rise to danger. This requirement does not apply if each pressure vessel in the system has a product of pressure in bar and internal volume in litres less than 250 bar litres. At the annual maintenance it is normal to test the high pressure installation to the working pressure.
- 9.2.2 Regulators for gas equipment should be inspected annually by a competent person, and both regulators and flashback arrestors should be replaced at intervals of five years or as recommended by the supplier. Gas hoses and their connectors should be inspected regularly to ensure that they remain in good condition. Cracked or perished hoses must be replaced, and the hoses should be replaced every five years even if apparently in good condition.
- 9.2.3 After any breakdown in which the pipework has been, or could have been disturbed, it should be leak tested.

9.3 Ventilation System and Dust Disposal

- 9.3.1 All extraction systems provided for operator protection, including dry extraction systems must be examined every 14 months by a competent person. Dry extraction systems should be regularly monitored to ensure that the plant is operating correctly. This ensures that problems are identified early and will also increase the life expectancy of consumable items since the system can be adjusted at this time to provide maximum performance. The ducting should be examined, cleaned, and the

condition of the filter should be monitored, personnel must wear suitable respiratory protection.

- 9.3.2 It is important that the extraction and abatement systems are not ignored, and users must consider these aspects in addition to the spray system. It is important that the system is viewed holistically and maintained as one piece of plant as this will ensure that the plant works at its most effective with minimal downtime and problems.
- 9.3.3 Cleaning of the booth should be carried out using a vacuum cleaner designed to handle hazardous dusts, fitted with a high efficiency particulate arrestor (HEPA) filter.
- 9.3.4 When bag changing on dry collection systems personnel will need respiratory protective equipment where there is a risk of exposure to dusts that are hazardous to health.
- 9.3.5 All waste must be disposed of in a safe and environmentally responsible manner.

9.4 Wet Systems

- 9.4.1 The water system will become contaminated with the particulate matter in the overspray. For at least part of the year, the temperature of the water will be within the range where bacteria will grow freely, with ideal growing conditions provided by the particulates, and there is therefore a risk of colonisation by legionella pneumophila.¹⁷ For this reason, the water system will need to be assessed and if considered a foreseeable risk, adequately controlled. The control regime should include appropriate biocides and regular cleaning and maintenance of the system. A drain-down and clean is an important parts of the control regime. The frequency of such activities will depend on the use of the equipment. Monitoring for micro-organisms using dipslides may be required weekly. The assessment will need to determine these factors. Contaminated water should be treated as hazardous waste.
- 9.4.2 Advice should be sought from a competent contractor in drawing up a written scheme for the care of the system.

9.5 Electrical Maintenance

- 9.5.1 All portable and transportable electrical equipment shall be maintained in a safe condition, and tested at regular intervals. Advice is given in the Health and Safety Executive guidance.⁶¹ The definition of portable and transportable includes all equipment of 18 kg or less which is not fixed, and heavier equipment that has wheels, etc, to facilitate movement.⁶² This work should only be undertaken by competent persons.
- 9.5.2 The fixed installation should also be the subject of an appropriate maintenance scheme in accordance with guidance in BS 7671.⁵⁰

9.5.3 Records should be kept of all inspections and tests including any tests where new equipment is installed.

10. Contingencies and emergency provisions

- 10.1 The employer's risk assessment for the equipment should include foreseeable emergencies.
- 10.2 The effect of a power cut should be assessed, in particular what effect it will have on the extraction systems and the safety of the area in the immediate aftermath, including the possibility of unexpected resumption of the power. Both engineering control measures and procedural control measures may be required.
- 10.3 The presence of thermal spray equipment could have a significant effect on the fire risk assessment for the building, and this should be reviewed and updated as necessary (see references¹² and³¹).
- 10.4 There are several foreseeable emergencies in respect of gases, including explosions, leaks, fires, and accidental damage to cylinders, all of which should be the subject of planning before they happen, to ensure that the damage to persons and property is minimised or eliminated. Emergency procedures for gases are given in BCGA Codes of Practice CP6³⁶, CP7³⁴, and CP4.³⁵ Alternatively the gas supplier may be contacted for advice.
- 10.5 More general emergency arrangements will include the provision of means of escape, fire fighting apparatus, and the provision of first aid arrangements.

11. References

1. Essentials of Health and Safety at Work, ISBN 0 7176 0716 X.
2. Management of Health and Safety at Work Regulations 1999 and ACOP, L21, ISBN 0 7176 2488 9.
3. Five steps to risk assessment, INDG163 (rev). Single free copies are available to download from the HSE website, priced packs of 10: ISBN 0 7176 1565 0.
4. Five steps to risk assessment, Case Studies HSG 183, ISBN 0 7176 1580 4.
5. Safe Use of Work Equipment. Provision and Use of Work Equipment Regulations 1998, L22, ISBN 0 7176 1626 6.
6. Manual Handling. Manual Handling Operations Regulations 1992, as amended, L23, ISBN 0 7176 2823 X.
7. Safe use of lifting equipment. Lifting Operations and Lifting Equipment Regulations 1998, L113, ISBN 0 7176 1628 2.
8. Workplace health, safety and welfare. Workplace (Health, Safety and Welfare) Regulations 1992, L24, ISBN 0 7176 0413 6.
9. Control of Noise at Work Regulations; Controlling Noise at work. Guidance on the Regulations L108, ISBN 0 7176 6164 4.
10. Control of Substances Hazardous to Health Regulations 2002, as amended; Approved code of practice and guidance, L5, ISBN 0 7176 2981 3.
11. Dangerous Substances and Explosive Atmospheres Regulations, 2002, Approved Code of Practice and Guidance, L138, ISBN 0 7176 2203 7.
12. Regulatory Reform (Fire Safety) Order 2005, SI 2005/1541.
13. Electricity at Work Regulations, 1989, Memorandum of Guidance, Second edition 2007, HSR25, ISBN 0 7176 6228 9.
14. Environmental Protection Act 1990.
15. Occupational Exposure Limits, Guidance Note EH 40, published annually.
16. Asthmagen? Critical assessments of the evidence for agents implicated in occupational asthma. Also known as the 'Asthmagen Compendium'; currently available as a free download from the HSE website:<http://www.hse.gov.uk/asthma/asthmagen.pdf>
17. Legionnaires Disease: The control of Legionella bacteria in water systems L8, ISBN 0 7176 1772 6.
18. BS EN 60079-10: 2003. Electrical apparatus for explosive gas atmospheres part 10: Classification of hazardous areas.
19. BS EN 50281-1-1 and -1-2 and BS EN 50281-1-3 Electrical apparatus for use in the presence of combustible dust.
20. Product Standards - Machinery: Guidance Notes on UK Regulations. Available from the DTI see the publications section on the website: <http://www.berr.gov.uk/>
21. BS EN ISO 12100 Parts 1 & 2: 2003, Safety of Machinery - Basic concepts, general principles for design (supersedes BS EN 292).
22. BS EN 953: 1998. Safety of machinery - guards - general requirements for the design and construction of fixed and movable guards.
23. BS EN 1088: 1996, plus A1: 2007. Safety of machinery - interlocking devices associated with guards - principles for design and selection.

24. BS EN ISO 14121-1:2007. Safety of machinery - risk assessment principles (supersedes BS EN 1050).
25. BS EN 60204-1: 2006. Safety of machinery - electrical equipment of machines - Part 1: general requirements.
26. BS EN 125: 1991 Specification for flame supervision devices for gas burning appliances, thermo electric types.
27. BS EN 161: 2002 Automatic shut off valves for gas burners and gas appliances.
28. BS EN ISO 13850: 2006 Safety of machinery - emergency stop equipment: principles for design (supersedes BS EN 418).
29. BS EN 954-1: 1997. Safety of machinery. Safety related parts of control systems. General principles for design.
30. Equipment and Protective Systems Intended for Use in Potentially Explosive Atmospheres Regulations 1996.
31. Fire Safety: an employers guide ISBN 011 341229 0.
32. British Compressed Gases Association Guidance Note 2: Safe Practice for the Storage of Gases in transportable Cylinders Intended for Industrial Use: Rev. 3, 2005.
33. The Pressure Systems Safety Regulations, 2000, L122, ISBN 0 7176 1767.
34. The safe use of oxy-fuel gas equipment (individual portable or mobile cylinder supply), British Compressed Gases Association publication CP7, Rev. 4 2004.
35. Industrial gas cylinder manifolds and distribution pipework/pipelines (excluding acetylene), British Compressed Gases Association publication CP4, Rev. 3, 2005.
36. The safe use of acetylene in the pressure range 0 to 1.5 bar, British Compressed Gases Association publication CP6, Rev. 1 1998.
37. The design and construction of manifolds using acetylene gas from 1.5 bar to a maximum working pressure of 25 bar, British Compressed Gases Association publication CP5.
38. The carriage of dangerous goods (classification, packaging and labelling) and use of transportable pressure receptacles regulations, 1996, L88, ISBN 0 7176 1221.
39. Explosives Act, certificate of exemption 2, 1989.
40. Safety in pressure testing, GS4 ISBN 0 7176 16290.
41. BS EN 559: 2003, Gas Welding Equipment: Rubber hoses for welding, cutting and allied processes.
42. BS EN 1256: 2006, Gas welding equipment - specification for hose assemblies for equipment for welding, cutting and allied processes.
43. Personal Protective Equipment at work 1992, Second edition, L25, ISBN 0 7176 6139 3.
44. Secretary of State's Guidance - Metal and Other Thermal Spraying Processes PG6/35 1996, ISBN 0 11 753281 9.
45. BS EN 1598: 1998 Health and safety in welding and allied processes. Transparent curtains, strips and screens for arc welding processes.
46. IRPA/INIRC Guidelines on limits of exposure to ultraviolet radiation of wavelengths between 180 nm and 400 nm incoherent optical radiation.
47. IRPA Guidelines on protection against non-ionising radiation; the collected publications of the IRPA non-ionising radiation committee, McGraw Hill 1991, ISBN 00803 60971.

48. American Conference of Governmental Industrial Hygienists, 'Threshold limit values for Chemical Substances and Physical Agents' (re-issued annually - always use the latest version.)
49. Industrial Robot Safety 2000, HSG 43, ISBN 0 7176 1310 0.
50. BS 7671: 2008, Requirements for electrical installations; IEE Wiring Regulations, 17th Edition.
51. BS EN 60079-14: 2003 Electrical apparatus for explosive gas atmospheres. Electrical installations for hazardous areas (other than mines).
52. PD60079-14: 2000, Guide to application of EN 60079-14 (now withdrawn)
53. BS EN 60529:1992 Specification for degrees of protection provided by enclosures (IP code).
54. BS EN 61508 series. Functional safety of electrical, electronic/programmable electronic safety-related systems.
55. BS EN ISO 14918: 1998 Approval testing of thermal sprayers.
56. Application of the manual handling operations regulations to gas cylinders, British Compressed Gases Association publication GN3, Rev. 1 2005.
57. BS EN 169: 2002, Personal eye protection - filters for welding and related techniques; transmittance requirements and recommended use.
58. BS EN 12021: 1999, Respiratory protective devices - compressed air for breathing apparatus (supersedes BS 4275).
59. Electricity at work: safe working practices HSG 85, ISBN 0 7176 2164 2.
60. BS EN 60079-17: 2007 Electrical apparatus for explosive gas atmospheres. Inspection and maintenance of electrical installations in hazardous areas (other than mines).
61. Maintaining portable and transportable electrical equipment HSG 107, ISBN 0 7176 2805 1.
62. Code of Practice for In-service Inspection and Testing of Electrical Equipment, Institution for Engineering and technology, 2001, ISBN 085296 7764.
63. [Dykhuisen R.C. and M.F. Smith, *Gas dynamic principles of cold spray*, J. Thermal Spray Technol., Vol. 7 (2), (1998), pp. 205-212]
64. [Van Steenkiste T.H., J.R. Smith, R.E. Teets, et al., *Kinetic spray coatings*, Surface and Coatings Technology, Vol. 111, (1999), pp.62-71]
65. Klassen T., Gärtner F., Schmidt T. et al., *Cold spraying: present status and future prospects*, TSS Cold Spray Conference, Akron, Ohio, US, Oct 8-9 2007]
66. Heriaud-Kraemer H, Montavon G, Hertert S, Robin H, Coddet C. Harmful risks for workers in thermal spraying: a review completed by a survey in a french company. Journal of Thermal Spray technology, 2003, Vol 12(4):542-554.
67. The website for the HSE is <http://www.hse.gov.uk/index.htm>.
68. HSE publications are available from HSE Books, PO Box 1999, Sudbury Suffolk, CO10 2WA (tel 01787 881165). <http://www.hsebooks.com/Books/>
69. British Compressed Gases Association publications are available from 14 Tollgate, Eastleigh, Hampshire SO53 3TG, telephone 023 8064 1488 <http://www.bcgga.co.uk/>

70. British Standards are available from British Standards Institution, 389 Chiswick High Road, London W4 4AL (tel 020 8996 7400). <http://www.bsi-global.com/en/>

Appendices: Worked Examples

The following pages contain some worked examples, based on actual installations. There are also some checklists and flowcharts, which may help you to undertake your own risk assessment. However, it must be stressed that the circumstances relating to each installation are unique, and you must apply the principles to your own situation, which may well differ in significant ways from those described.

CONTENTS

1. Thermal spray equipment pre-installation flowchart
This flowchart is designed to help you to structure your approach to installation of thermal spray equipment.
2. An equipment location checklist, for installations where flammable gases are to be used
3. An equipment location flowchart where flammable gases/fuels are to be used.
This flowchart and checklist will help you to decide whether your chosen location is suitable for the equipment. The more unwanted features you identify, the less suitable the area, so whenever you answer 'no' to a question, either you will need to make the appropriate remedial actions, or consider a different location. They may help as the precursor to carrying out preliminary Hazardous Area Classification, since their use will minimise retrospective remedial action.
4. Worked example illustrating the Zones arising from a Hazardous Area Classification
5. Checklist for the installation and commissioning of a fully enclosed thermal spray booth
6. System of work for spraying operations in an extracted booth
This case study is an example of how an older installation may be operated to control the risk of explosion from leaked gas. A new booth would have the extraction system interlocked with the gun controls. For existing systems, a risk assessment should be carried out to identify any additional control measures required as well as the elements of a safe system of work which should be in operation until they have been fitted. One effective means of ensuring that operators do not start the gun without adequate ventilation is to put a time delay on the lighting, which will not allow the lights to come on in the booth until the extraction system has been on long enough to achieve 5 volume changes of air in the booth.
7. Spraying in an open workshop using a lathe to traverse the work piece (any thermal spray system)
Operation in an open workshop makes greater demands on the system of work and personal protective equipment. The employer must carry out a risk assessment, and this must address at the very least noise, ultraviolet radiation (for plasma or arc spray), dust and fume, explosions, and physical hazards such as tripping and burning.
8. A Risk Assessment and Method Statement for a Spraying Operation Carried Out on Site - Anti Corrosion Treatment Using Zinc
This case study illustrates an assessment that was carried out for site work. The project entailed spraying zinc in an historic building using an arc spray unit. It illustrates how the spraying operation must be integrated into other aspects of the project, such as grit blasting, working at height, and painting.

Example 1: Thermal spray equipment pre-installation flowchart

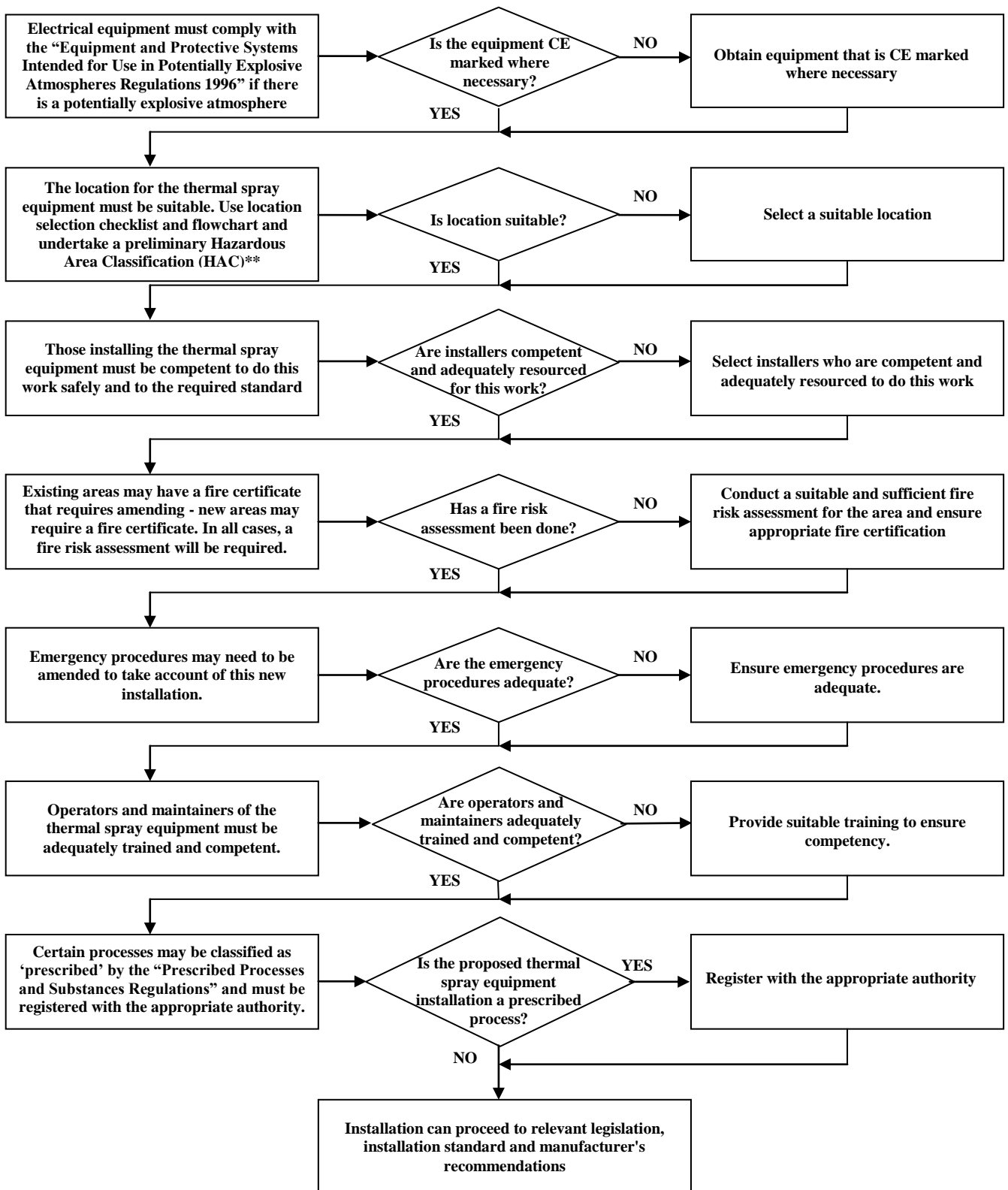

** Preliminary HAC estimates potential release sources and zoning to allow potential problems to be 'engineered out' before installation.

Example 2: EQUIPMENT LOCATION SELECTION CHECKLIST, for installations where flammable gases/fuels are to be used. (to be used in conjunction with the location selection flowchart and pre-installation flowchart)			
Nº	Question	Y/N	If answer is NO, list remedial actions or consider new location
1.	Is the proposed area single storey?		
2.	Does proposed area have sufficient space for process and suitable access?		
3.	Is there an accessible outside wall?		
4.	Can the process be located near to outside wall?		
5.	Can the gas supply be located externally, near to the process? (Note: care is needed in locating a gas that can re-liquefy)		
6.	Is there adequate access to gas supply?		
7.	Is proposed area adequately ventilated?		
8.	Is proposed area free from spaces where gas can collect?		
9.	Do processes nearby pose no risk to and are they at no risk from this process?		
10.	Can all potential sources of ignition be eliminated if the area is subsequently zoned?		
11.	Have manufacturer's location requirements been met?		
Type of Installation: Proposed Location: Assessor's Name: Assessor's Signature: Date:			

Example 3: EQUIPMENT LOCATION SELECTION FLOWCHART

For installations where flammable gases/fuels are to be used

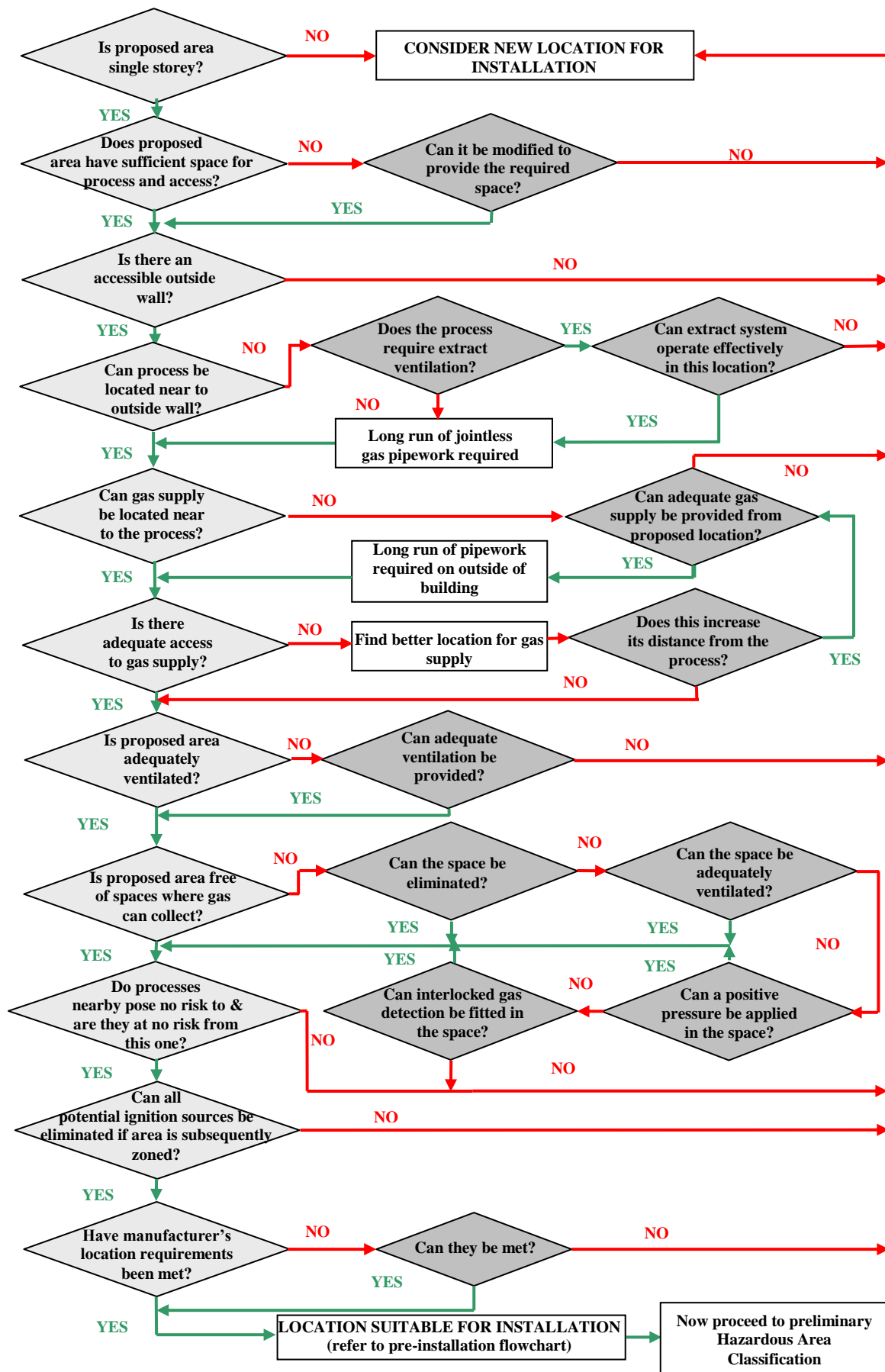

Example 4: An Example of Zoning after Hazardous Area Classification

High Velocity Oxy-fuel (HVOF) and Plasma Spray Area

New equipment, to be installed in an existing single-storey open plan building. There are two spray booths:

HVOF: Supplied with, and capable of operating with, acetylene, hydrogen, kerosene or propylene. The fuel is supplied from external storage, the kerosene (flash-point 63°C) is contained in a small header tank on an outside wall, the acetylene, hydrogen, propylene and oxygen are supplied from an external cylinder gas storage area. (Note, care will be needed in locating any gas that can liquefy). The storage area is of 'breeze-block' construction and each gas has its own bay. All pipework, from the connection at the cylinder storage and kerosene header tank, to the booth is jointless – all sections being welded or brazed (dependent on material of pipes). All regulators are located within the fully ventilated, interlocked booth that is fitted with high and low-level gas detection.

Plasma: This is supplied with argon, nitrogen and hydrogen, coming from the cylinder gas storage area. The regulator is on the outside of the booth, but has gas detection fitted above it. The booth is fully ventilated and interlocked, with high-level gas detection fitted.

The gas mixing units on both the HVOF and Plasma Spray facilities are separate from the control panel, thereby minimising the risk of ignition.

The general ventilation in the area is less than adequate, but work is in progress so that the booths take some of their 'make-up' air from within the building itself, thus improving the level of general ventilation and reducing the extent of the zones. **

The following page shows the Zones that resulted from the Hazardous Area Classification (HAC).

** The effect of reducing the extent of the zone was to remove the need to modify electrical apparatus, because it was now outside the zoned area. The plant cannot be used until the ventilation modifications, i.e. interlocking with the electrical supply, have taken place. It should be noted that the integrity of ventilation systems is critical where safety is totally dependent on its operation.

HAZARDOUS AREA CLASSIFICATION ZONE DIAGRAM OF HVOF/PLASMA SPRAY FACILITIES

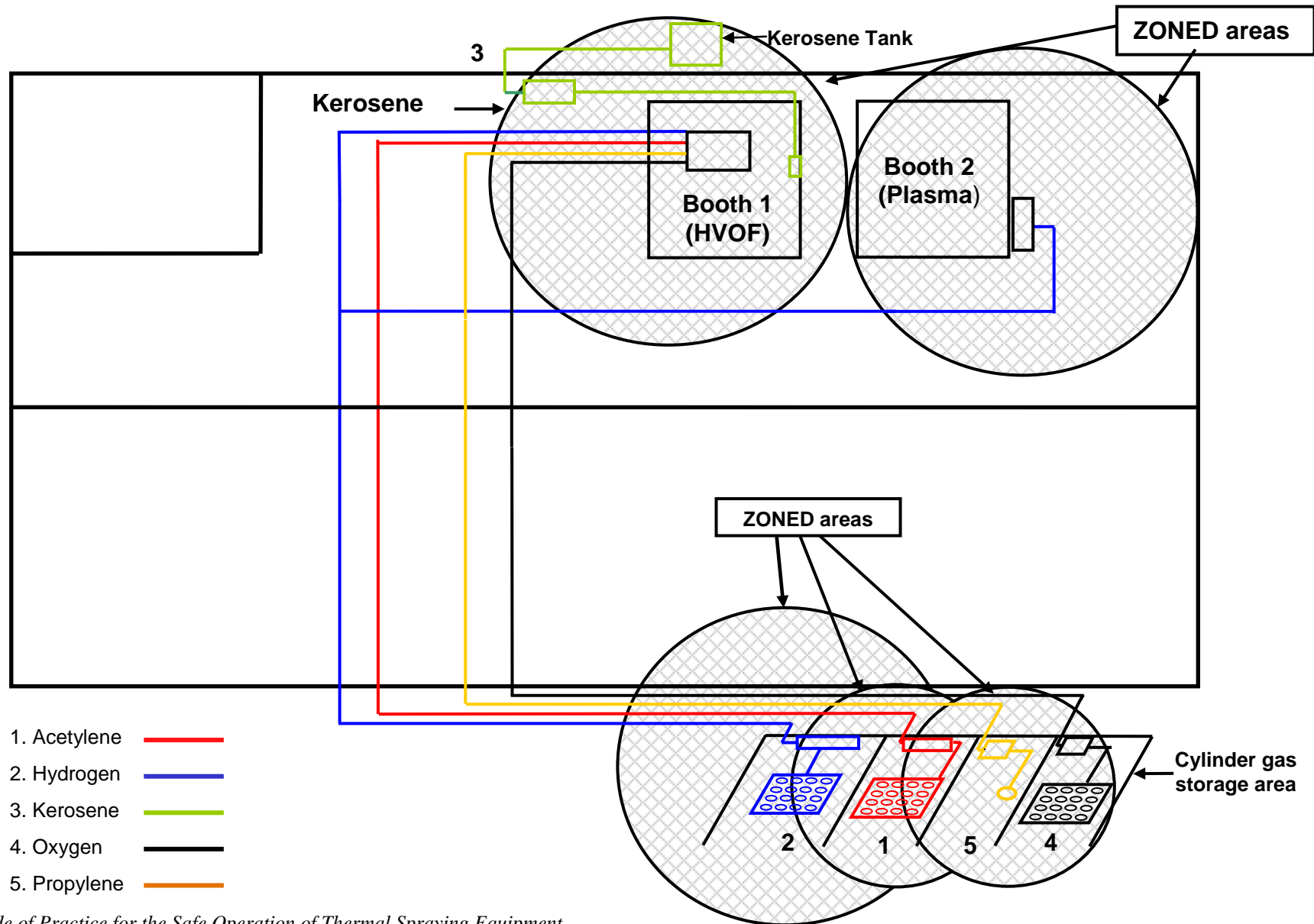

Example 5: Checklist for the Installation and Commissioning of a Fully Enclosed Thermal Spray Booth

Fully enclosed Thermal Spray Booth (controlled externally via interface)

Identify the hazards of the process, which may include:

	YES ✓	NO ✗
Flammable/explosive gases or liquids	<input type="checkbox"/>	<input type="checkbox"/>
Pressure	<input type="checkbox"/>	<input type="checkbox"/>
Dust and Fumes	<input type="checkbox"/>	<input type="checkbox"/>
Ultra Violet Radiation	<input type="checkbox"/>	<input type="checkbox"/>
Fire, explosion	<input type="checkbox"/>	<input type="checkbox"/>
Physical Hazards i.e., hot material, tripping	<input type="checkbox"/>	<input type="checkbox"/>
Electric shock	<input type="checkbox"/>	<input type="checkbox"/>
Noise	<input type="checkbox"/>	<input type="checkbox"/>
Electrostatic discharge	<input type="checkbox"/>	<input type="checkbox"/>

Considerations when installing the process:

Conduct pre-installation inspection of the work area

	YES	NO
<ul style="list-style-type: none"> Consider where the compressed gas pipelines will be situated. Aim to reduce sources of release to an absolute minimum, e.g. by the use of welded or brazed joints. This can be aided by installing the maximum amount of pipe work and connections that carry flammable/explosive gases on the outside of the external walls to the buildings. 	<input type="checkbox"/>	<input type="checkbox"/>
<ul style="list-style-type: none"> Locate compressed gas cylinder storage area out of doors, and identify and locate suitable emergency shut off valves. 	<input type="checkbox"/>	<input type="checkbox"/>
<ul style="list-style-type: none"> Ideally, the proposed compressed gas storage area must be located adjacent to an external wall of the building. 	<input type="checkbox"/>	<input type="checkbox"/>
<ul style="list-style-type: none"> Identify what level of ventilation is available in the area and its impact on the HAC. The greater the level of ventilation the lower the risk of creating a potentially explosive atmosphere (should a release of flammable gas occur) 	<input type="checkbox"/>	<input type="checkbox"/>
<ul style="list-style-type: none"> Ensure the roof of the building is not designed in such a way that any released gases could be trapped in voids or similar structural features. Ensure there are no cellars, pits, trenches also. 	<input type="checkbox"/>	<input type="checkbox"/>
<ul style="list-style-type: none"> Consider what sources of ignition exist within the proposed work area. Ask yourself can they be eliminated, removed, or reduced. 	<input type="checkbox"/>	<input type="checkbox"/>

Considerations during Installation of the process

- Have competent persons been employed to install the pipe work and gas storage facility? Is the system installed to British Compressed Gas Association (BCGA) standards and fitted with slam-shut valves and flash back arrestors etc? YES
 NO

- Review the work equipment being installed to ensure its safety, does the equipment have a ‘CE’ mark affixed? YES
 NO

- Consult with the equipment supplier and/or manufacturer as to the proposed location of the equipment. YES
 NO

- Is there adequate control of the contractors/suppliers working on the system, taking account of the HS&E requirements? YES
 NO

Obtain additional relevant information from the equipment suppliers

- Is the equipment/system fitted with suitably located and sufficient emergency stops to ensure the system can close down safely and quickly in an emergency? YES
 NO

- Are all the emergency stops linked to ensure that if one is activated, then all the system closes down safely? YES
 NO

- If the equipment detects a safety critical fault, e.g. a flammable gas leak, a failure in the purge air system or similar will the equipment close down automatically to a safe condition? YES
 NO

- What gas detection units will the equipment supplier be installing, and what are the locations within that equipment? YES
 NO

- Is the electrical equipment that is located within a potentially explosive atmosphere suitable to be used in this type of environment in line with the HAC? YES
 NO

- Identify if the local exhaust ventilation (LEV) fitted to the spray booths is interlocked to the gas supply, i.e. when the LEV is not operating then the gas will not be supplied. YES
 NO

- Is the exhaust air flow rate monitored? YES
 NO

- | | | |
|--|---|--|
| <ul style="list-style-type: none"> • Obtain a copy of the information that the equipment supplier has prepared for the customer to indicate how he has complied with each of the Essential Health and Safety Requirements under the Supply of Machinery Regulations, and other relevant Regulations?²⁰ (Note: the full information is confidential, but he should be able to state the standards to which the equipment conforms). | <p>YES
<input type="checkbox"/></p> | <p>NO
<input type="checkbox"/></p> |
| <ul style="list-style-type: none"> • Identify noise emission levels supplied by the equipment supplier | <p>YES
<input type="checkbox"/></p> | <p>NO
<input type="checkbox"/></p> |

Considerations when the installation has been completed

- | | | |
|---|---|--|
| <ul style="list-style-type: none"> • A written scheme of examination should be obtained for the complete system from a competent person. | <p>YES
<input type="checkbox"/></p> | <p>NO
<input type="checkbox"/></p> |
| <ul style="list-style-type: none"> • The recommended service, maintenance and repair requirements specified by the manufacturer should be identified and implemented. | <p>YES
<input type="checkbox"/></p> | <p>NO
<input type="checkbox"/></p> |
| <ul style="list-style-type: none"> • The Fire Certificate applicable to the premises will need to be amended to reflect the alterations made to the building. Any fire risk assessments should be reviewed to ensure they accurately represent the status of the building. | <p>YES
<input type="checkbox"/></p> | <p>NO
<input type="checkbox"/></p> |
| <ul style="list-style-type: none"> • Any site emergency procedure should be amended to reflect the current location of the equipment and the associated hazards. | <p>YES
<input type="checkbox"/></p> | <p>NO
<input type="checkbox"/></p> |
| <ul style="list-style-type: none"> • Appropriate warning signs will need to be installed around the work area to warn of hazards relating to the process. | <p>YES
<input type="checkbox"/></p> | <p>NO
<input type="checkbox"/></p> |
| <ul style="list-style-type: none"> • Has suitable training been given to the operator of the equipment? | <p>YES
<input type="checkbox"/></p> | <p>NO
<input type="checkbox"/></p> |
| <ul style="list-style-type: none"> • Ensure other possible ignition sources are not introduced into the area after the installation has been completed, e.g. battery charging. | <p>YES
<input type="checkbox"/></p> | <p>NO
<input type="checkbox"/></p> |
| <ul style="list-style-type: none"> • Having completed the installation of the equipment and associated pipe work, a hazardous area classification is required. This identifies the sources of release and grade of release and ultimately allows the user of the equipment to zone the area. | <p>YES
<input type="checkbox"/></p> | <p>NO
<input type="checkbox"/></p> |

- | | | |
|--|--|---------------------------------------|
| <ul style="list-style-type: none"> Having completed the hazardous area classification using BS EN 60079-10¹⁸ the appropriate electrical equipment can be selected for use in the work area from BS EN 60079-14.⁵¹ | YES
<input type="checkbox"/> | NO
<input type="checkbox"/> |
| <p>Carry out a noise assessment</p> | YES
<input type="checkbox"/> | NO
<input type="checkbox"/> |

Foreseeable causes of incidents

- Leakage of flammable gases due to damaged hoses or connectors.
- Leakage due to inadequate design, specification or installation of associated equipment.
- Failure to secure joints/connections.
- Inadequate ventilation
- Failure to undertake 'leak testing' on the systems joints/ connections
- Contact with Plasma/Combustion Arc or hot components
- Safety devices bypassed or overridden
- Failure to inspect, and/ or maintain equipment
- Ignition caused by naked flame, smoking or unsuitable electrical equipment/fittings.
- Failure to follow safe system of work.

Consequences

- Fire and/or explosion leading to: -
- fatality, blindness, noise induced hearing loss, loss of limb, burns, laceration, bruising, etc and/or damage to buildings plant or equipment
- Business interruption, industrial relations problems, adverse publicity.

Example 6: System of work for spraying operations in an extracted booth

Note: this case study refers to an existing system. In new installations, a higher standard of interlocking is required, see Worked Example 5.

Installation

Plasma and HVOF units have been sited in an extracted booth. The spraying equipment is manipulated by a robot. Components are either manipulated by an indexing turntable or held stationary in a fixture. Components are manually loaded into the booth and processed in a sealed booth via control panels outside the booth in a semi-automatic operation. This booth does not have its extraction system interlocked with the gun controls, and hence the risk of explosion or asphyxiation from gases within the booth, which may have accumulated due to a leak, is controlled by a system of work based on a risk assessment.

Start up procedure

1. Turn on extraction prior to entry, and allow time for 5 volume changes.
2. Ensure booth is in a safe condition to operate access, equipment, gun condition, etc.,
3. Power up equipment and check function prior to use.

Operation

1. Before loading components, ensure equipment is safe, i.e. spray unit is non-operational, robot is locked out. A safe working system is required for operators to enter the booth if either or both the spray equipment and robot is in operation. E-stops should be positioned in booth.
2. Provision should be made for loading/unloading of large parts, parts of awkward shape or parts with sharp edges. Rotating parts should be tooled to minimise risk of slippage from rotation unit.
3. Access and escape routes from the booth should be marked and kept clear.
4. Check operation of equipment, ensure air-lines, powder lines, power cables etc are free to allow equipment movement without catching.
5. Ensure extraction, which in the case of a new installation should be interlocked, is in operation prior to spraying, and has been in operation long enough to achieve 5 volume changes of air in the booth.
6. Access to booth should be restricted whilst equipment is in operation, e.g. by interlocking.
7. Noise levels should be measured and operator noise exposure assessed. Hearing protection should be issued as required. Signs should be erected.
8. After spraying sufficient time should be allowed for extraction unit to evacuate dust and fumes. Provision should be made to either allow parts to cool before handling or personal protective equipment should be provided to handle hot parts.
9. Consider relevant personal protective equipment for the handling of powders and filling hoppers. This should also be considered during the cleaning up of spills and during cleaning of booths.
10. Disposal of waste powder should be controlled, in respect of dust release and hazardous wastes.

Shut down

1. Leave booth in a safe condition, i.e. no trailing hoses or cables.
2. Power off and turn off gases at source; then purge out pressurised lines and turn off water cooling.

Example 7: Spraying in an open workshop using a lathe to traverse the work piece (any thermal spray system)

Operation in an open workshop makes greater demands on the system of work and personal protective equipment. The employer must carry out a risk assessment, and this must address at the very least noise, ultraviolet radiation (for plasma or arc spray), dust and fume, ignition hazards, and physical hazards such as tripping and burning.

Location

Without the benefit of a purpose built booth, the operation should be sited carefully and the timing of spraying operations may need to be tailored to the needs of others. The noisiest spraying operations are not suitable to locations close to people. Hazardous Area Classification is required to define safe distances between the operation and any flammable or combustible materials. It will also determine the distance that it must be from any electrical switchgear, and the zone within which the electrical apparatus must be of approved type.

Ventilation

The user must undertake a risk assessment to ensure that control of exposure to fume and dust is in accordance with the Control of Substances Hazardous to Health Regulations.¹⁰ Adequate precautions must be taken to control exposure to dust and fume and to ensure that concentrations of flammable gases cannot build up to dangerous levels. Forced ventilation should be used wherever reasonably practicable, but in some instances where the risk is very low it may be handled by segregation and natural ventilation. Typically forced ventilation should take the form of an extractor hood or flanged slot mounted along the length of the lathe in line with the spray system traverse and positioned to receive dust from the rotating lathe. The air should be extracted at a rate that captures dust effectively, typically 1 m/s at the lathe. Extraction efficiency and running costs can be optimised by siting the opening close to the workpiece and enclosing as much of the lathe as is reasonably practicable. If forced ventilation is required then it must be started sufficiently in advance of spraying and stopped with sufficient delay after cessation of spraying to ensure that dust, fume and gases have been adequately dispersed.

If it is not practicable to ensure respirable air by means of ventilation, then suitable personal protective equipment shall be used by all at risk. For the operator in particular, respiratory protective equipment will almost certainly be required, for example an air-fed helmet. The supply air must be of breathable quality, free from fumes and oil mists and meeting BS EN 12021 (formerly BS4275).⁵⁸ All skin should be covered, as dust can irritate the skin.

Connections

Setting up must be in accordance with the equipment manufacturer's instructions. Whenever a piece of equipment is moved connections will be undone and re-made. It is essential that all connections are checked to ensure their integrity. Gas connections should be leak tested and electrical connections should be checked visually. Bear in mind that in arc processes currents of many hundreds of Amps can flow and that badly made joints can generate enough heat to melt the metal connections. No gas

connection should be over-tightened. If a gas connection still leaks after a reasonable force has been used then the fitting is damaged or faulty and must be replaced.

Often, when operating in an open workshop, some part of the machine such as the power supply may be remote. This leads to trailing leads and the possibility of tripping accidents. The trailing leads or hoses are much more prone to accidental damage, which may lead to a gas leak or electrical fault. Leads should be as short as possible and have flexible armouring where they are liable to be damaged. Power leads and gas hoses should never contain joints.

Spraying

Care must be taken to ensure that any spray or over spray does not impinge on any flammable or degradable materials. A sheet of metal may be used as a backstop, or a temporary booth if available.

Noise

A simple hanging PVC barrier can attenuate the noise by up to 10 dB, so that hanging temporary barriers round the work can have a significant effect. The operator will almost certainly need hearing protection, and a noise assessment is advised. Absorptive acoustic barriers may be erected around the machine.

Ultraviolet Radiation

For any process producing UV light, eyes must be protected. For plasma spraying a shade 9 welding filter, according to BS EN 169⁵⁷, or for arc spraying a shade 6 is the minimum. Fast reacting welding masks of the relevant shade may also be used. The radiation from plasma spraying may cause skin damage through light clothing, so thick or aluminised clothing is required. Scattered radiation can affect the line between gloves and sleeves, and the underside of the chin and nose.

Shutdown

Turn off gas at source and back off the regulators, purge and depressurise the lines, leave the ventilation on to clear the fume.

Training and competence

During all stages, the operations must be carried out by competent persons. This is true for the risk assessment itself, and all the installation work.

Example 8: A Risk Assessment and Method Statement for a Spraying Operation Carried Out on Site - Anti Corrosion Treatment Using Zinc

Hazard	Risks	Persons Affected	Control of Risk
Metal Spraying & metal fume fever	Respiratory problems, eye injury	Metal spray operator	Work is carried out in a fully enclosed cubicle that has extraction fitted within it. The operator is supplied with full protective equipment.
Overhead crane usage, using slings etc	Falls of loads from slings due to incorrect slinging. Overloading of cranes. Head injury	Operatives and employees in the area	Operators have received slings and lifting training. All persons must wear head protection at all times.
Grit blast process, dust, flying grit	Eye injury, respiratory problems	Grit blast operator	Operator supplied with full protective equipment and work is carried out within a fully enclosed cubicle
Noise	Noise induced hearing loss.	All employees and visitors within the area.	Ear protection is compulsory for grit blast and metal spraying operators. It is recommended for others in the near vicinity with noise exposures between 85 and 89 dB(A). (Subject to a noise assessment)
Falls from height	Injury, possibly fatal	Employees and contractors working on platforms, scaffold or ladders	Free-standing scaffold platforms and towers are used which provide protection from falls
Use of ladders	Injury, possibly fatal	All employees within the area	Ladders must be non-conductive (e.g. wood, polypropylene) and be footed by another employee or tied at the top.
Air compressors	Failure of compressed air reservoir	Employees within shop and sprayer	The maintenance engineer maintains compressors and they are inspected daily

Hazard	Risk	Persons Affected	Control of Risk
Paint application by brush/roller techniques Xylene fume	Respiratory problems, flammable vapours (serious explosion risk with xylene)	All employees and visitors within vicinity of the works	A COSHH assessment must be carried out together with air monitoring details, and measures instituted to control exposure. These are in a separate file. Painters are provided with all the necessary protective equipment. Antistatic precautions may need to be made when handling xylene.
Fire	Burns, smoke inhalation	All employees and visitors within the vicinity of the works	All employees must receive training in the use of fire extinguishers. NO SMOKING POLICY APPLIES
Housekeeping fire hazards	Fire, tripping hazards	All employees	Tins of paint and flammable items are kept in a separate area. NO SMOKING applies in the area at the works. The working area is kept clean and tidy on a daily basis.

Method Statement

Phase 1

Erect working enclosure – to be carried out by others
 Grit blast to remove dirt and existing paint using wet blasting techniques
 Clear debris and spent abrasive, place in closed containers
 Inspection by third party; repairs to be carried out (by others) if required

Phase 2

Connect extraction unit to tented area
 Grit blast
 Clear spent abrasive from area and ensure that surfaces are clean and dry
 Inspect - taking random samples
 Inspect working enclosure for damage; repair as necessary
 Zinc metal spray within 4 hours of grit blasting
 Inspect
 Spray sealer within 4 hours of metal spraying
 Inspect
 Paint procedure (3 iterations)
 Apply proprietary paint
 Inspect
 Remove all debris and ensure all surfaces are clean
 Conduct final inspection
 Dismantle working enclosure
 Issue certificate of conformity and all coating treatment records